

SOFFIANTI E ASPIRATORI A CANALE LATERALE

- Serie CL e Tipo TBT

SIDE CHANNEL BLOWERS AND EXHAUSTERS

- CL Series and TBT Type

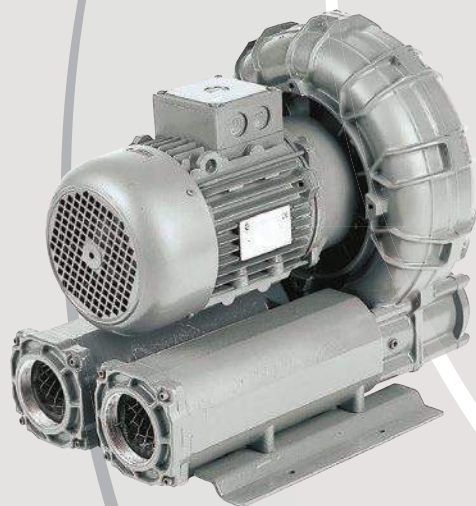
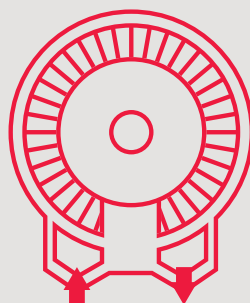

ISO 9001 - Cert. 1835



MAPRO

MACCHINE A CANALE LATERALE - Serie CL

SIDE CHANNEL MACHINES - CL Series

Principio di funzionamento

Il principio di funzionamento delle macchine a canale laterale consiste nell'incrementare la pressione del gas aspirato tramite la creazione, nel canale toroidale periferico, di una serie di vortici determinati dalla spinta centrifuga del rotore alettato. Con la girante in rotazione, le palette spingono il gas in avanti e, per effetto della forza centrifuga, verso l'esterno. Ne risulta un moto elicoidale, durante il quale il gas subisce una serie di ricompresioni dovute alla forza centrifuga, con conseguente incremento lineare di pressione lungo il canale.

Operating principle

The side channel blower or exhauster increases the pressure of the aspirated gas by the creation, in the peripheral toroidal channel, of a series of vortices caused by the centrifugal thrust of the impeller. While the impeller is rotating, the vanes force the gas forward and, because of the centrifugal thrust, outwards, producing a helical motion. During this motion, the gas is recompressed repeatedly with a consequent linear pressure increase along the length of the channel.

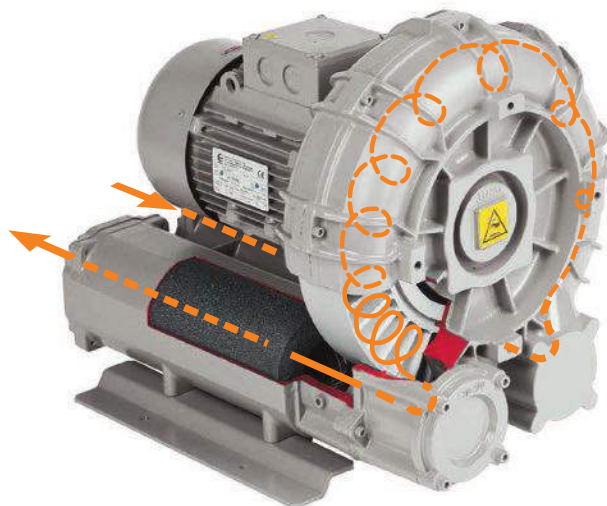

Applicazioni e vantaggi

Le soffianti a canale laterale sono adatte per tutte quelle applicazioni ove si richiedano pressioni sensibilmente più elevate dei normali ventilatori centrifughi. Gli aspiratori ove occorra una depressione più elevata di quella fornita da un ventilatore, ma non tanto da richiedere l'impiego di una pompa per vuoto. Le parti in movimento non sono tra di loro in contatto. Non essendoci attrito e non essendo quindi necessaria nessuna lubrificazione, il gas convogliato non viene assolutamente inquinato. Oltre a questo, i più elevati vantaggi nell'utilizzo delle macchine a canale laterale sono:

- massima semplicità di installazione;
- rumorosità molto contenuta;
- assenza di vibrazioni e quindi completa stabilità;
- assenza di pulsazioni nel gas trattato;
- minima manutenzione.

Applications and advantages

Side channel blowers are suitable for all those applications requiring considerably higher pressures than that which can be achieved using centrifugal fans. Side channel exhausters are used in all those applications requiring an operating vacuum higher than the one achievable by a fan, but not as high as to require the use of a vacuum pump. The rotating parts are not in contact with the casing. There is therefore no friction during operation and thus no internal lubrication is necessary. The gas moving through the machine therefore remains uncontaminated and completely oil-free. The other main advantages of using side channel machines are:

- easy installation;
- low noise level;
- no vibration and therefore complete dynamic stability;
- pulsation free discharge;
- minimal maintenance.

Campo di utilizzo

Range of duty

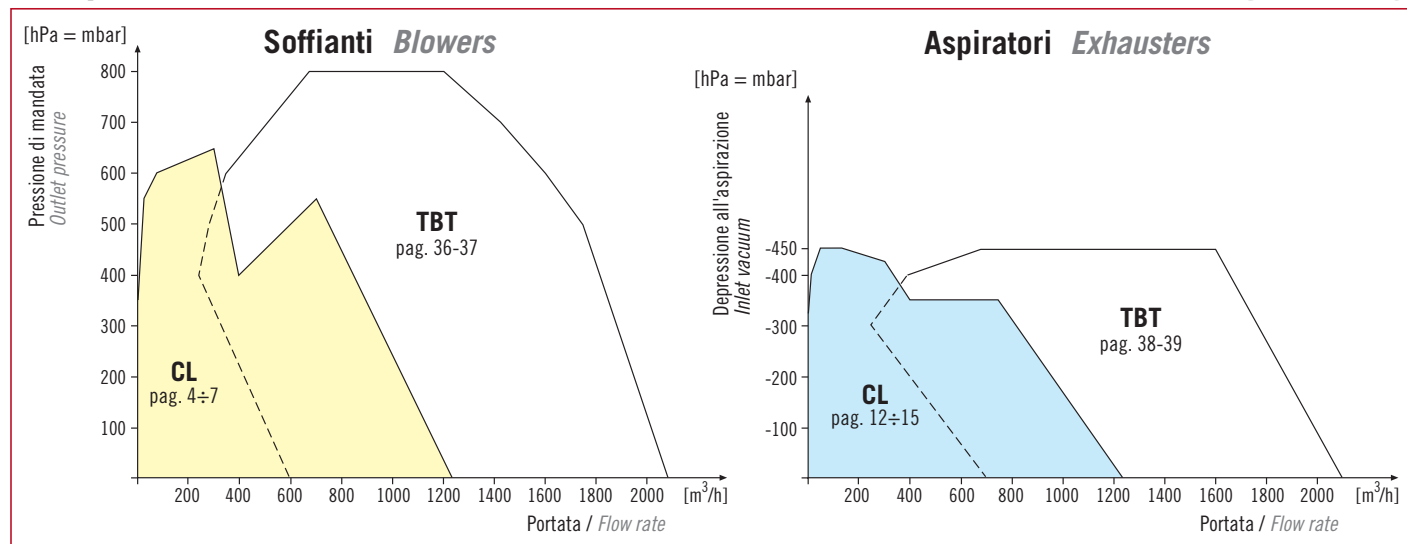

Note tecniche di costruzione

- Carcasce e giranti sono interamente realizzate in lega di alluminio.
- La costruzione standard, per aria, è in esecuzione "MONOBLOCCO". La flangia anteriore del motore elettrico costituisce cioè anche il fondo della macchina lato motore e la girante, bilanciata dinamicamente, è calettata sul capo d'albero del motore stesso.
- I motori elettrici, per servizio continuo, sono a due poli, disponibili in versione trifase per tutte le potenze indicate in catalogo, ed in versione monofase, a 50 Hz, fino a 2,2 kW. Sono costruiti secondo le norme IEC con le seguenti caratteristiche standard:

- per le macchine senza suffisso HS e di tipo diverso da CL 1R e CL 2R:

grado di protezione: - IP 55

classe d'isolamento: - F per potenze fino a 3 kW

- H per potenze uguali o superiori a 4 kW

tensioni di alimentazione:

Rete	Frequenza	Potenza motore	Tensione d'alimentazione
3 - ph	50 Hz	≤ 3 kW	230 VΔ / 400 VΛ
3 - ph	50 Hz	≥ 4 kW	400 VΔ / 690 VΛ
1 - ph	50 Hz	≤ 2,2 kW	230 V
3 - ph	60 Hz	≤ 3,6 kW	265 VΔ / 460 VΛ
3 - ph	60 Hz	≥ 4,8 kW	460 VΔ / 795 VΛ

Per alimentazione a 50 Hz, la variazione di tensione ammessa è ± 10%, conformemente alla Norma IEC 60038. Per alimentazione a 60 Hz, così come per motori costruiti su richiesta con valori di tensione, a 50 Hz o 60 Hz, diversi dallo standard, la variazione di tensione ammessa è ± 5%, conformemente alla Norma IEC 60034.

- per le macchine con suffisso HS:

grado di protezione: - IP54

classe d'isolamento: - F

tensioni di alimentazione:

Rete	Frequenza	Potenza motore	Tensione d'alimentazione
3 - ph	50 Hz	≤ 3 kW	200~240 VΔ / 345~415 VΛ
3 - ph	50 Hz	≥ 4 kW (●)	345~415 VΔ / 595~720 VΛ
1 - ph	50 Hz	≤ 1,5 kW	104~127 V / 208~254 V
1 - ph	50 Hz	2,2 kW	230~242 V
3 - ph	60 Hz	≤ 3,45 kW	208~275 VΔ / 380~480 VΛ
3 - ph	60 Hz	≥ 4,6 kW (●)	380~480 VΔ / 660~720 VΛ

(●) fa eccezione la CL 60 HS 4/4,6 kW il cui motore, nella versione standard, è costruito per tensione d'alimentazione:

a 50 Hz : 200~240 VΔ / 345~415 VΛ

a 60 Hz : 208~275 VΔ / 380~480 VΛ

- per le macchine CL 1R e CL 2R:

grado di protezione: - IP54

classe d'isolamento: - F

tensioni di alimentazione:

Rete	Frequenza	Potenza motore	Tensione d'alimentazione
3 - ph	50 Hz	0,7 - 1,6 - 2,2 kW	200~240 VΔ / 345~415 VΛ
3 - ph	50 Hz	≥ 7,5 kW	345~415 VΔ / 600~720 VΛ
1 - ph	50 Hz	0,7 kW	220~240 V
3 - ph	60 Hz	0,83-2,05-2,55 kW	220~275 VΔ / 380~480 VΛ
3 - ph	60 Hz	≥ 8,6 kW	380~480 VΔ / 660~720 VΛ

- Le macchine rispondono alle norme generali previste dalle Direttive Europee 2006/42 (Macchine), 2006/95 (Bassa Tensione), 2004/108 (Compatibilità Elettromagnetica) ed alle norme armonizzate applicabili.

Accessori

Per tutte le macchine è stata sviluppata una linea completa di accessori che comprende: filtri a cartuccia per soffianti - filtri di linea per aspiratori - manicotti flessibili di collegamento - valvole di ritegno - valvole di sovrappressione per soffianti - valvole rompivuoto per aspiratori - manometri e vuotometri - cabine insonorizzanti.

Technical and constructional features

- Casings and impellers are made of aluminium alloy.
- The standard machines for air are manufactured in the so-called "CLOSE COUPLED" version; i.e. the front shield of the electric motor is also the machine motor-side casing half. The impeller, which is dynamically balanced, is fitted directly onto the motor shaft extension.
- The two-pole electric motors, designed for continuous operation, are available in three phase for all the powers shown in the catalogue and in single phase, at 50 Hz, up to 2.2 kW. They are manufactured according to IEC Specifications with the following standard features:

- for machines without HS suffix and other than CL 1R and CL 2R:

degree of protection: - IP 55

insulation class: - F for powers up to 3 kW

- H for powers 4 kW and above

line voltages:

Main	Frequency	Motor power	Line voltage
3 - ph	50 Hz	≤ 3 kW	230 VΔ / 400 VΛ
3 - ph	50 Hz	≥ 4 kW	400 VΔ / 690 VΛ
1 - ph	50 Hz	≤ 2,2 kW	230 V
3 - ph	60 Hz	≤ 3,6 kW	265 VΔ / 460 VΛ
3 - ph	60 Hz	≥ 4,8 kW	460 VΔ / 795 VΛ

For 50 Hz supply, the allowed voltage variation is ± 10% according to IEC 60038 Standard.

For 60 Hz supply, as well as for motors specifically requested for any other voltage at 50 Hz or at 60 Hz, a ± 5% tolerance on supply voltage is allowed, in accordance with IEC 60034 Standard.

- for machines with HS suffix:

degree of protection: - IP54

insulation class: - F

line voltages:

Main	Frequency	Motor power	Line voltage
3 - ph	50 Hz	≤ 3 kW	200~240 VΔ / 345~415 VΛ
3 - ph	50 Hz	≥ 4 kW (●)	345~415 VΔ / 595~720 VΛ
1 - ph	50 Hz	≤ 1,5 kW	104~127 V / 208~254 V
1 - ph	50 Hz	2,2 kW	230~242 V
3 - ph	60 Hz	≤ 3,45 kW	208~275 VΔ / 380~480 VΛ
3 - ph	60 Hz	≥ 4,6 kW (●)	380~480 VΔ / 660~720 VΛ

(●) with the exception of CL 60 HS 4/4,6 kW whose motor, in the standard version, is manufactured for the line voltages:

at 50 Hz : 200~240 VΔ / 345~415 VΛ

at 60 Hz : 208~275 VΔ / 380~480 VΛ

- for machines CL 1R and CL 2R:

degree of protection: - IP54

insulation class: - F

line voltages:

Main	Frequency	Motor power	Line voltage
3 - ph	50 Hz	0,7 - 1,6 - 2,2 kW	200~240 VΔ / 345~415 VΛ
3 - ph	50 Hz	≥ 7,5 kW	345~415 VΔ / 600~720 VΛ
1 - ph	50 Hz	0,7 kW	220~240 V
3 - ph	60 Hz	0,83-2,05-2,55 kW	220~275 VΔ / 380~480 VΛ
3 - ph	60 Hz	≥ 8,6 kW	380~480 VΔ / 660~720 VΛ

- The machines meet the requirements of the European Directives 2006/42 (Machines), 2006/95 (Low Voltage), 2004/108 (Electromagnetic Compatibility) and of the applicable harmonised Standards.

Accessories

A complete range of accessories is available for all machines: cartridge type filters for blowers - in-line filters for exhausters - flexible hoses - non return valves - pressure relief valves for blowers - vacuum relief valves for exhausters - pressure and vacuum gauges - acoustic enclosures.

4

MAPRO

50 Hz**Soffianti con motori a 50 Hz (2900 giri/min)
Blowers with 50 Hz motors (2900 rpm)**

Nota / Note:

La maggior parte delle soffianti per aria è disponibile anche in esecuzione per
Zone 1 e 2, 21 e 22 della Direttiva Europea 94/9/CE (ATEX).Most of the blower models for air are also manufactured in conformity to the requi-
rements of the European Directive 94/9/EC (ATEX) for Zones 1 and 2, 21 and 22.**Diagramma portate-pressioni****Flow rate-pressure diagram**

Key

Machine type	Motor power (kW)
60/1	11
2R9	25

Legend

- 60/1: Machine type
- 2R9: Motor power (kW)

Pressure of supply [hPa = mbar] (Left Y-axis, 0 to 650)

Outlet pressure [hPa = mbar] (Right Y-axis, 0 to 650)

Flow rate [m³/h] (Bottom X-axis, 0 to 1300)

Flow rate [m³/h] (Top X-axis, 0 to 1300)

Portata [m³/h] (Right Y-axis, 0 to 1300)

Flow rate [m³/h] (Right Y-axis, 0 to 1300)

Portate riferite ad aria a 20°C e 1013 mbar ass.
Flow rates refer to air at 20°C and 1013 mbar abs.

50 Hz

Soffianti a 50 Hz (2900 giri/min) Blowers at 50 Hz (2900 rpm)

		Salto di temperatura °C - Temperature rise °C																
Pressione di mandata Outlet pressure [hPa = mbar]		50	100	150	175	200	225	250	300	350	400	425	450	500	550	600	625	650
Tipo Soffiante Blower Type	CL 20 HS	14																
	CL 30-Z HS	11	27															
	CL 3.6/01	9	17	31														
	CL 4/01	11	23	41	53													
	CL 7/01	8	18	30	37	43												
	CL 1R3.5	13	28	52														
	CL 10/01	10	17	27	33	39	45											
	CL 40 HS	9	17	29	38	54												
	CL 15/01	10	17	26	31	37	42	48										
	CL 50 HS	11	20	32	40	48	58	69										
	CL 18/01	8	14	24	29	35	41	48	62									
	CL 1R5.5	13	21	32	39	48	59	74										
	CL 60 HS	13	21	30	35	42	51	62	89									
	CL 28/1	7	12	20	25	30	36	42	56	73	95							
	CL 22/01	12	21	31	36	41	46	51	62									
	CL 34/1	9	16	22	27	32	37	44	57	72	88							
	CL 40/1	13	19	26	30	34	38	43	54	65	80	88	99					
	CL 80-Z HS	10	17	25	29	35	40	46	59	77	99							
	CL 46/1	9	15	21	25	29	34	39	51	64	78	87	96					
	CL 60/1	8	15	23	27	32	37	42	53	68	85	95						
	CL 72/1	12	17	25	29	34	39	45	58	73	90	100						
	CL 1R9	14	19	27	32	37	42	48	61	77	96							
	CL 84/1	12	18	24	28	32	37	42	53	66	82							
	CL 98/1	15	21	28	32	36	40	45	55	67	81	89	99					
	TBT/M	18	24	31	35	39	42	46	54	62	72	77	82	96				
	CL 4/21	13	21	30	35	40	46	52	67									
	CL 7/21	7	13	20	25	29	33	38	46	55								
	CL 220 HS	9	16	25	29	35	49											
	CL 10/21	11	19	29	34	39	44	49	61	73	86							
	CL 12/21	8	13	19	22	26	29	33	40	47	54	57	61	70	81			
	CL 420 HS	12	18	24	28	33	38	43	55	69	88							
	CL 14/21	7	12	17	20	23	26	30	37	46	56	61	66	77	88			
	CL 17/21	13	17	22	25	28	31	35	42	51	60	65	70	81	94			
	CL 520 HS	14	18	23	26	30	34	38	48	59	72	79	86					
	CL 20/21	9	16	23	27	31	34	38	45	52	61	65	70	79	90	102		
	CL 23/21	12	16	21	24	27	30	33	40	47	54	58	62	71	81	92	99	
CL 720 HS	14	20	26	30	33	36	40	47	55	64	69	74	86	99				
CL 30/21	10	16	22	25	28	31	35	42	50	58	62	67	77	88	99			
CL 36/21	14	20	27	30	33	36	40	47	54	62	66	71	81	91	103			
CL 42/21	12	16	20	23	26	29	32	39	47	55	60	65	76	87	100			
CL 2R8	19	24	29	32	35	38	42	49	57	66	71	76	87	99				
CL 49/21	14	19	25	28	32	35	39	46	53	61	65	69	77	85	94	99	105	
CL 2R9	20	24	28	31	34	37	40	47	55	64	68	73	84	96				

Tolleranza: ± 5 °C - Tolerance: ± 5 °C

		Rumorosità dB(A) ad 1m Sound level dB(A) at 1m							
Pressione di mandata Outlet pressure [hPa = mbar]		50	150	200	250	300	350	400	450
Tipo Soffiante Blower Type	CL 20 HS	68							
	CL 30-Z HS	69							
	CL 3.6/01	70	72						
	CL 4/01	72	75						
	CL 7/01	75	77	77					
	CL 1R3.5	69	70						
	CL 10/01	71	72	73					
	CL 40 HS	70	73	76					
	CL 15/01	73	74	75	76				
	CL 50 HS	72	76	76	77				
	CL 18/01	73	74	75	76	77			
	CL 1R5.5	72	73	74	75				
	CL 60 HS	77	78	78	79	80			
	CL 28/1	75	79	81	83	84	85	85	
	CL 22/01	75	76	76	77	78			
	CL 34/1	74	75	77	78	79	79	80	
	CL 40/1	77	78	80	80	81	81	82	83
	CL 80-Z HS	76	77	79	80	80	81	82	
	CL 46/1	79	79	80	80	81	82	83	83
	CL 60/1	79	80	80	81	82	82	82	
	CL 72/1	78	80	82	82	83	83	84	
CL 1R9	76	78	79	81	82	84	85		
CL 84/1	80	82	83	83	84	84	85		
CL 98/1	79	80	81	82	82	83	84	85	
TBT/M	79	80	81	82	82	83	83	83	

		Rumorosità dB(A) ad 1m Sound level dB(A) at 1m							
Pressione di mandata Outlet pressure [hPa = mbar]		100	200	300	400	450	500	550	600
Tipo Soffiante Blower Type	CL 4/21	72	73	74					
	CL 7/21	73	73	74					
	CL 220 HS	69	71						
	CL 10/21	72	72	73	75				
	CL 12/21	71	73	73	75	77	78	78	
	CL 420 HS	75	75	77	78				
	CL 14/21	70	72	73	74	75	76	77	
	CL 17/21	70	71	72	74	75	76	78	
	CL 520 HS	74	74	75	76	76			
	CL 20/21	71	73	74	74	75	75	76	78
	CL 23/21	78	79	82	83	83	83	83	83
	CL 720 HS	74	74	74	74	75	75	76	
	CL 30/21	77	78	79	80	81	81	82	82
	CL 36/21	79	79	79	80	80	81	81	81
	CL 42/21	80	81	83	83	84	84	85	85
	CL 2R8	78	78	79	79	80	80	80	
	CL 49/21	78	79	81	82	83	84	85	86
CL 2R9	79	81	82	83	83	85	85		

La rumorosità è intesa come livello di pressione sonora Lp, misurato in campo libero, in accordo alla Norma EN ISO 2151.
Tolleranza sui valori di rumorosità: ± 2 dB(A).

The noise level is intended as sound pressure level (SPL), measured in free field, in accordance with the Standard EN ISO 2151.
Tolerance on sound level values: ± 2 dB(A).

50 Hz

Soffianti - prestazioni con motori a 50 Hz Blowers - performance with 50 Hz motors

Pressione di mandata Outlet pressure $hPa = mbar$		0	50	75	100	125	150	175	200	225	250	275	300												
Portata aspirata - Flow rate		m³/h		m³/h		m³/h		m³/h		m³/h		m³/h		m³/h											
Potenza motore - Motor power		kW		kW		kW		kW		kW		kW		kW											
Tipo Soffiante	CL 20 HS	54	22	0,22	[0 m³/h a/at 70 mbar]																				
	CL 30-Z HS	84	54	0,4	39	0,4	24	0,4	9	0,4	[6 m³/h a/at 130 mbar]														
	CL 3.6/01	35	25	0,25	20	0,25	15,5	0,25	11	0,25	6	0,25													
	CL 4/01	52	38	0,37	31	0,37	24	0,37	18	0,37	11	0,37	4	0,37											
	CL 7/01	80	62	0,55	53	0,55	44	0,55	35	0,55	25	0,55	16	0,75	7	0,75									
	CL 1R3.5	116	84	0,7	68,5	0,7	53	0,7	37,5	0,7	22	0,7													
	CL 10/01	120	100	0,75	90	0,75	80	0,75	70	0,75	60	1,1	50	1,1	40	1,1	30	1,1							
	CL 40 HS	150	118	0,9(●)	103	0,9(●)	89	0,9(●)	74	0,9(●)	59	0,9(●)	44	1,1	30	1,1									
	CL 15/01	176	149	1,1	135	1,1	122	1,1	108	1,1	95	1,1	81	1,5	68	1,5	54	1,5	41	1,5					
	CL 50 HS	212	184	1,5	168	1,5	151	1,5	133	1,5	116	1,5	99	1,5	82	1,5	65	2,2	50	2,2					
	CL 18/01	252	218	1,5	201	1,5	184	1,5	167	1,5	151	2,2	134	2,2	118	2,2	101	2,2	85	3	68	3	52	3	
	CL 1R5.5	270	232	1,6	213	1,6	194	1,6	175	1,6	156	1,6	137	1,6	118	2,2	99	2,2	80	2,2					
	CL 60 HS	300	268	2,2	249	2,2	230	2,2	211	2,2	192	2,2	174	2,2	155	3	136	3	117	3	100	4	82	4	
	CL 28/1	310	270	2,2	250	2,2	232	2,2	216	2,2	200	2,2	186	2,2	173	3	160	3	147	3	134	3	121	4	
	CL 22/01	346	306	2,2	286	2,2	266	2,2	246	2,2	226	3	206	3	186	3	167	4	148	4	128	4	108	4	
	CL 34/1	380	348	3	333	3	317	3	301	3	285	3	269	3	254	4	238	4	223	4	207	5,5	191	5,5	
	CL 40/1	454	416	3	397	3	378	3	360	3	343	4	326	4	310	4	294	5,5	278	5,5	262	5,5	246	5,5	
	CL 80-Z HS	518	472	4	449	4	426	4	403	4	380	4	357	4	334	4	311	5,5	288	5,5	265	5,5	242	5,5	
	CL 46/1	575	512	4	485	4	460	4	436	4	415	4	394	5,5	375	5,5	356	5,5	338	5,5	320	7,5	303	7,5	
	CL 60/1	685	620	4	590	4	563	4	537	4	512	5,5	488	5,5	464	5,5	440	7,5	416	7,5	392	7,5	368	9,2	
	CL 72/1	820	750	4	718	4	687	4	656	4	625	5,5	594	5,5	563	7,5	532	7,5	502	7,5	471	9,2	441	9,2	
	CL 1R9	1038	962	8,5	924	8,5	886	8,5	848	8,5	810	8,5	772	8,5	734	12,5	696	12,5	658	12,5	620	12,5	582	18,5	
	CL 84/1	1065	990	5,5	952	5,5	914	5,5	876	7,5	838	7,5	800	9,2	762	9,2	723	9,2	684	11	645	11	606	11	
	CL 98/1	1120	1055	7,5	1022	7,5	990	7,5	957	9,2	925	9,2	892	11	860	11	827	11	795	15	762	15	730	15	
	Blower Type	TBT/M	1235	1162	11	1126	11	1090	11	1054	11	1020	11	990	15	960	15	932	15	905	15	877	15	850	18,5
		CL 4/21	54	46	0,55	42	0,55	38	0,55	34	0,55	30	0,55	26	0,55	22	0,55	18	0,75	14	0,75	10	0,75	6	0,75
	CL 7/21	80	70	1,1	65	1,1	60	1,1	54	1,1	49	1,1	44	1,1	38	1,1	33	1,1	28	1,1	22	1,1	17	1,1	
	CL 220 HS	86	72	0,8	65	0,8	58	0,8	51	0,8	44	0,8	37	0,8	31	0,8	24	0,8	16	0,8	3	0,8			
	CL 10/21	120	107	1,5	101	1,5	94	1,5	88	1,5	81	1,5	75	1,5	68	1,5	62	1,5	55	1,5	49	1,5	42	2,2	
	CL 12/21	130	114	1,1	107	1,1	100	1,1	93	1,1	87	1,1	81	1,1	75	1,5	70	1,5	65	1,5	61	1,5	57	1,5	
	CL 420 HS	154	138	1,6(●)	130	1,6(●)	122	1,6(●)	114	1,6(●)	106	1,6(●)	98	1,6(●)	90	1,6(●)	82	1,6(●)	74	1,6(●)	66	2,2	58	2,2	
	CL 14/21	160	142	1,1	134	1,1	127	1,1	120	1,1	114	1,1	108	1,5	102	1,5	96	1,5	91	1,5	86	1,5	81	2,2	
	CL 17/21	205	189	2,2	181	2,2	173	2,2	165	2,2	158	2,2	150	2,2	143	2,2	135	2,2	127	3	119	3	112	3	
	CL 520 HS	236	220	3	212	3	203	3	194	3	185	3	176	3	167	3	158	3	149	3	140	3	131	3	
	CL 20/21	235	216	2,2	208	2,2	200	2,2	193	2,2	186	2,2	180	2,2	174	2,2	168	3	162	3	156	3	150	3	
	CL 23/21	280	254	3	243	3	233	3	223	3	215	3	207	3	200	3	193	3	186	3	180	4	174	4	
	CL 720 HS	324	306	3	297	3	288	3	279	3	270	3	261	3	252	3	243	3	234	4,3	225	4,3	216	4,3	
	CL 30/21	350	328	3	317	3	306	3	295	3	285	3	276	3	268	3	260	4	252	4	244	4	236	4	
	CL 36/21	410	387	4	375	4	363	4	351	4	340	4	328	4	317	4	305	5,5	294	5,5	283	5,5	273	5,5	
	CL 42/21	525	496	5,5	483	5,5	470	5,5	458	5,5	445	5,5	433	5,5	420	5,5	408	5,5	395	7,5	383	7,5	370	7,5	
	CL 2R8	548	523	7,5	511	7,5	499	7,5	487	7,5	475	7,5	463	7,5	451	7,5	439	7,5	427	7,5	415	7,5	403	7,5	
	CL 49/21	600	560	5,5	544	5,5	530	5,5	517	5,5	504	5,5	491	5,5	478	5,5	466	5,5	454	7,5	442	7,5	430	7,5	
	CL 2R9	1080	1044	12,5	1026	12,5	1008	12,5	990	12,5	972	12,5	954	12,5	936	12,5	918	16,5	900	16,5	882	16,5	864	16,5	

I valori di portata sono riferiti ad aria alle condizioni d'aspirazione di 20°C e 1013mbar ass.

Tolleranza sui valori di portata: ±10%

(●) CL 40 HS motore trifase: 0,9kW - motore monofase: 0,8kW

(●) CL 420 HS motore trifase: 1,6kW - motore monofase: 1,5kW

(2900 giri/min)
(2900 rpm)



Nota / Note:

La maggior parte delle soffianti per aria è disponibile anche in esecuzione per Zone 1 e 2, 21 e 22 della Direttiva Europea 94/9/CE (ATEX).

Most of the blower models for air are also manufactured in conformity to the requirements of the European Directive 94/9/EC (ATEX) for Zones 1 and 2, 21 and 22.

325		350		375		400		425		450		475		500		525		550		575		600		625		650			
m³/h		m³/h		m³/h		m³/h		m³/h		m³/h		m³/h		m³/h		m³/h		m³/h		m³/h		m³/h		m³/h		m³/h			
	kW		kW		kW		kW		kW		kW		kW		kW		kW		kW		kW		kW		kW		kW		
108	4	96	4	84	4	72	4																						
175	5,5	160	5,5	145	5,5	130	5,5																						
230	7,5	214	7,5	198	7,5	183	7,5	167	7,5	152	7,5																		
219	7,5	196	7,5	173	7,5	150	7,5																						
285	7,5	268	7,5	250	9,2	232	9,2	213	9,2	190	9,2																		
344	9,2	320	9,2	296	11	273	11	250	11																				
412	11	383	11	354	15	325	15	296	15																				
544	18,5	506	18,5	468	18,5	430	18,5																						
567	15	528	15	489	15	450	15																						
697	18,5	665	18,5	632	18,5	600	18,5	567	18,5	530	18,5																		
825	18,5	800	18,5	775	22	750	22	725	22	700	22	675	25	650	25														
12	1,1	7	1,1																										
36	2,2	30	2,2	24	2,2	18	2,2																						
53	2,2	49	2,2	45	2,2	42	2,2	38	2,2	35	2,2	31	3	28	3	24	3	21	3										
50	2,2	42	2,2	34	2,2	26	2,2																						
76	2,2	72	2,2	67	2,2	63	2,2	58	3	54	3	50	3	47	3	44	3	41	3										
106	3	100	3	94	3	89	3	85	4	80	4	76	4	73	4	70	4	67	4										
122	3	113	3	104	3	95	3	86	4	77	4	68	4	[65 m³/h a/at 480 mbar]															
144	3	138	3	131	4	125	4	119	4	113	4	107	5,5	101	5,5	95	5,5	89	5,5	83	5,5	77	5,5						
168	4	162	4	156	5,5	150	5,5	144	5,5	138	5,5	132	5,5	126	5,5	120	5,5	114	5,5	108	7,5	102	7,5	95	7,5				
207	4,3	198	4,3	189	4,3	180	5,5	171	5,5	162	5,5	153	5,5	144	5,5	135	7,5	126	7,5										
228	5,5	220	5,5	212	5,5	204	5,5	196	7,5	188	7,5	180	7,5	172	7,5	164	7,5	157	7,5	149	7,5	142	7,5						
264	7,5	255	7,5	246	7,5	238	7,5	230	7,5	222	7,5	214	7,5	206	7,5	198	9,2	190	9,2	182	9,2	174	9,2						
358	7,5	346	7,5	334	7,5	322	7,5	310	9,2	298	9,2	286	9,2	274	9,2	262	11	250	11	238	11	225	11						
391	7,5	379	7,5	367	11	355	11	343	11	331	11	319	11	307	11	294	11	280	11										
419	7,5	408	7,5	398	9,2	388	9,2	379	9,2	370	9,2	361	11	352	11	343	11	334	11	325	15	317	15	308	15	300	15		
846	16,5	828	20	810	20	792	20	774	20	756	20	738	25	720	25	702	25	684	25										

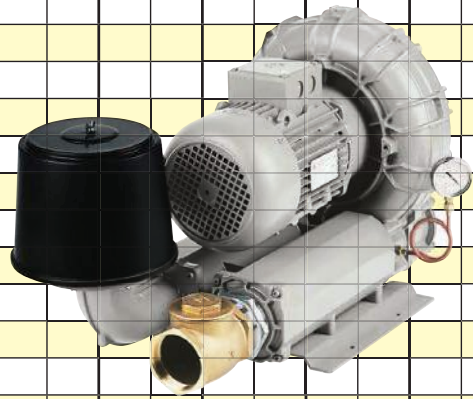

Flow rates refer to air at the suction conditions of 20°C and 1013mbar abs.
Tolerance on flow rate values: ±10%

- (●) CL 40 HS three phase motor: 0,9kW - single phase motor: 0,8kW
- (●) CL 420 HS three phase motor: 1,6kW - single phase motor: 1,5kW

88

MAPRO

60 Hz

Soffianti con motori a 60 Hz (3500 giri/min)

Blowers with 60 Hz motors (3500 rpm)



Nota / Note:

La maggior parte delle soffianti per aria è disponibile anche in esecuzione per Zone 1 e 2, 21 e 22 della Direttiva Europea 94/9/CE (ATEX).
Most of the blower models for air are also manufactured in conformity to the requirements of the European Directive 94/9/EC (ATEX) for Zones 1 and 2, 21 and 22.

Diagramma portate-pressioni

Flow rate-pressure diagram

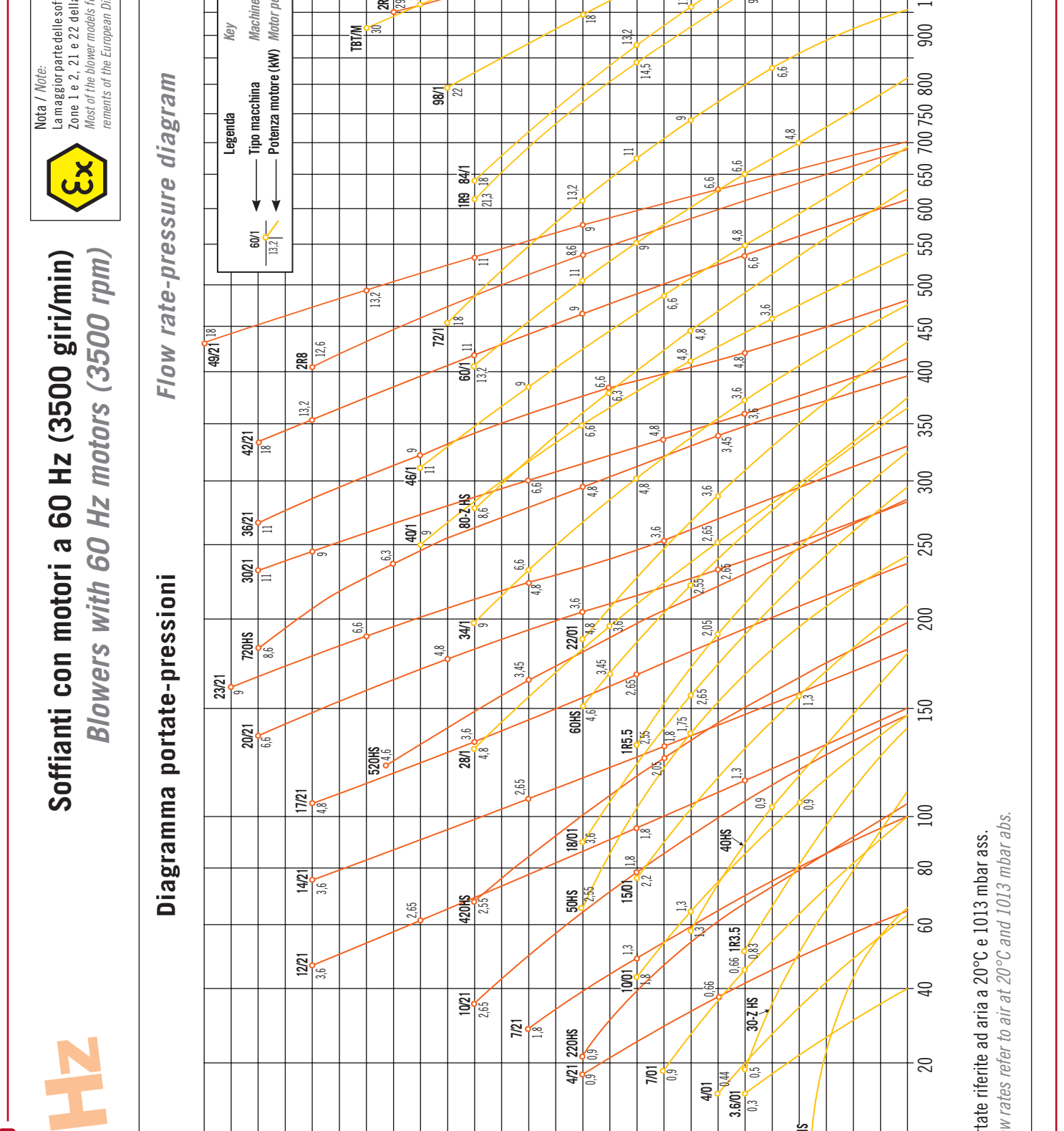

Legend

- 60/1: Tipo macchina (Machine type)
- 13.2/1: Potenza motore (kW) (Motor power (kW))

key

- Machine type
- Motor power (kW)

Portata [m³/h] / **Flow rate** [m³/h]

Pressione di mandata [hPa = mbar] / **Outlet pressure** [hPa = mbar]

Portate riferite ad aria a 20°C e 1013 mbar ass.

Flow rates refer to air at 20°C and 1013 mbar abs.

60 Hz

Soffianti a 60 Hz (3500 giri/min) Blowers at 60 Hz (3500 rpm)

		Salto di temperatura °C - Temperature rise °C																
Pressione di mandata Outlet pressure [hPa = mbar]		50	100	150	175	200	225	250	300	350	400	425	450	500	550	600	625	650
Tipo Soffiante Blower Type	CL 20 HS	12																
	CL 30-Z HS	9	19	41														
	CL 3.6/01	10	17	28														
	CL 4/01	12	22	36	47													
	CL 7/01	11	18	28	34	41	52											
	CL 1R3.5	14	28	46														
	CL 10/01	12	18	26	32	39	48	59										
	CL 40 HS	9	16	25	32	40												
	CL 15/01	13	19	26	30	35	40	46										
	CL 50 HS	12	17	25	30	36	43	51	73									
	CL 18/01	11	16	24	29	34	40	46	58									
	CL 1R5.5	16	22	32	38	46	56	68										
	CL 60 HS	13	19	26	31	37	43	50	72									
	CL 28/1	8	15	22	26	31	36	41	53	67	86							
	CL 22/01	15	22	30	35	40	45	50	60									
	CL 34/1	10	16	22	27	31	35	40	50	63	79							
	CL 40/1	13	19	26	30	34	38	43	53	63	75	82	89					
	CL 80-Z HS	13	17	25	29	33	37	42	53	68	87							
	CL 46/1	11	16	23	26	30	34	39	49	60	74	81	90					
	CL 60/1	10	16	23	27	31	35	40	50	62	76							
	CL 72/1	15	21	28	32	37	42	47	57	70	85	94						
	CL 1R9	16	22	29	33	38	43	48	60	74	90							
	CL 84/1	14	20	26	29	33	37	42	51	63	78							
	CL 98/1	18	25	33	37	41	45	49	57	66	78	85						
	TBT/M	20	27	34	37	41	44	48	55	62	69	74	79	90				
	CL 4/21	14	22	30	34	39	44	50	63									
	CL 7/21	9	14	20	24	28	32	36	44	52								
	CL 220 HS	9	15	22	26	32	38	47	70									
	CL 10/21	15	21	29	33	37	42	47	58	69	82							
	CL 12/21	11	15	19	22	24	27	30	36	43	51	55	59	67	78			
	CL 420 HS	13	16	22	25	28	33	37	48	60	74							
	CL 14/21	12	16	22	25	28	31	34	40	47	54	58	62	71	82			
CL 17/21	13	17	21	24	27	30	33	40	48	56	60	65	75	85				
CL 520 HS	15	18	23	25	29	33	36	44	53	64	70	77						
CL 20/21	13	18	23	26	29	32	36	43	51	59	63	67	76	86	97			
CL 23/21	15	19	24	26	29	31	34	40	46	53	56	60	69	78	89	97		
CL 720 HS	18	21	25	27	31	34	37	44	50	57	62	66	76	83				
CL 30/21	13	18	24	27	30	33	36	42	48	55	59	63	72	82	94			
CL 36/21	19	24	30	33	36	39	42	48	55	62	66	70	78	88	99			
CL 42/21	18	23	28	31	33	36	39	45	51	58	62	66	75	86	97			
CL 2R8	24	28	33	36	39	42	45	52	59	67	71	76	86	96				
CL 49/21	19	25	31	34	37	40	43	49	55	62	65	69	77	85	93	97	102	
CL 2R9	32	36	41	43	46	49	52	60	68	78	83	88						

Tolleranza: ± 5 °C - Tolerance: ± 5 °C

		Rumorosità dB(A) ad 1m Sound level dB(A) at 1m							
Pressione di mandata Outlet pressure [hPa = mbar]		50	150	200	250	300	350	400	450
Tipo Soffiante Blower Type	CL 20 HS	69							
	CL 30-Z HS	69	76						
	CL 3.6/01	72	74						
	CL 4/01	74	76						
	CL 7/01	77	78	79					
	CL 1R3.5	69	71						
	CL 10/01	74	75	76	77				
	CL 40 HS	72	74	76					
	CL 15/01	74	75	76	77				
	CL 50 HS	73	76	76	77	78			
	CL 18/01	75	76	77	78	78			
	CL 1R5.5	72	74	75	76				
	CL 60 HS	78	78	78	79	80			
	CL 28/1	78	79	81	83	84	85	85	
	CL 22/01	77	78	79	80	80			
	CL 34/1	78	79	79	80	80	80	81	
	CL 40/1	78	79	80	81	82	82	83	83
	CL 80-Z HS	78	79	81	82	82	83	83	
	CL 46/1	79	80	80	81	82	83	84	84
	CL 60/1	80	80	81	81	82	83	84	
CL 72/1	82	84	84	85	86	86	86		
CL 1R9	79	80	81	82	83	83	85		
CL 84/1	82	83	85	86	86	87	87		
CL 98/1	82	84	85	86	86	87	87		
TBT/M	81	82	83	83	84	84	85	85	

		Rumorosità dB(A) ad 1m Sound level dB(A) at 1m							
Pressione di mandata Outlet pressure [hPa = mbar]		100	200	300	400	450	500	550	600
Tipo Soffiante Blower Type	CL 4/21	74	76	77					
	CL 7/21	75	77	78					
	CL 220 HS	73	75	78					
	CL 10/21	75	75	76	78				
	CL 12/21	77	78	79	79	79	79	79	
	CL 420 HS	76	78	78	79				
	CL 14/21	76	77	77	78	78	79	79	
	CL 17/21	78	78	79	79	80	80	80	
	CL 520 HS	75	77	77	78	78			
	CL 20/21	74	75	76	76	77	77	78	79
	CL 23/21	81	82	82	83	83	83	83	83
	CL 720 HS	79	79	79	79	79	79	79	
	CL 30/21	81	81	82	83	83	83	83	84
	CL 36/21	82	83	83	83	84	84	84	84
	CL 42/21	82	83	84	84	85	85	86	86
	CL 2R8	80	80	81	81	82	82	82	
CL 49/21	83	84	85	85	85	86	86	87	
CL 2R9	82	83	84	86	86				

La rumorosità è intesa come livello di pressione sonora Lp, misurato in campo libero, in accordo alla Norma EN ISO 2151.
Tolleranza sui valori di rumorosità: ± 2 dB(A).

The noise level is intended as sound pressure level (SPL), measured in free field, in accordance with the Standard EN ISO 2151.
Tolerance on sound level values: ± 2 dB(A).

(3500 giri/min)
(3500 rpm)



Nota / Note:

La maggior parte delle soffianti per aria è disponibile anche in esecuzione per Zone 1 e 2, 21 e 22 della Direttiva Europea 94/9/CE (ATEX).

Most of the blower models for air are also manufactured in conformity to the requirements of the European Directive 94/9/EC (ATEX) for Zones 1 and 2, 21 and 22.

325		350		375		400		425		450		475		500		525		550		575		600		625		650				
m ³ /h	kW	m ³ /h	kW	m ³ /h	kW	m ³ /h	kW	m ³ /h	kW	m ³ /h	kW	m ³ /h	kW	m ³ /h	kW	m ³ /h	kW	m ³ /h	kW	m ³ /h	kW	m ³ /h	kW	m ³ /h	kW	m ³ /h	kW			
169	4,8	156	4,8	143	4,8	130	4,8																							
249	6,6	232	6,6	215	9	197	9																							
330	9	314	9	298	9	282	9	266	9	250	9																			
334	8,6	312	8,6	290	8,6	268	8,6																							
406	9	387	9	367	11	348	11	328	11	309	11																			
480	13,2	456	13,2	432	13,2	408	13,2																							
579	18	547	18	515	18	483	18	451	18																					
726	21,3	688	21,3	650	21,3	612	21,3																							
757	18	718	18	679	18	640	18																							
915	22	885	22	855	22	825	22	795	22																					
1095	22	1070	22	1045	26	1020	26	995	26	970	26	945	30	920	30															
34	1,8	28	1,8																											
56	2,65	49	2,65	42	2,65	35	2,65																							
81	2,65	77	2,65	73	2,65	69	2,65	65	2,65	61	2,65	57	3,6	53	3,6	49	3,6	45	3,6											
92	2,55	84	2,55	76	2,55	68	2,55																							
113	2,65	108	2,65	104	3,6	99	3,6	95	3,6	90	3,6	86	3,6	82	3,6	78	3,6	75	3,6											
146	3,6	140	3,6	134	3,6	128	3,6	123	4,8	118	4,8	114	4,8	111	4,8	108	4,8	105	4,8											
171	3,45	163	3,45	154	4,6	146	4,6	137	4,6	129	4,6	120	4,6	[117 m ³ /h a/at 480 mbar]																
196	4,8	191	4,8	185	4,8	180	4,8	174	4,8	169	6,6	163	6,6	158	6,6	152	6,6	147	6,6	141	6,6	136	6,6							
228	4,8	223	4,8	217	6,6	212	6,6	206	6,6	200	6,6	194	6,6	188	6,6	182	9	176	9	170	9	164	9	160	9					
285	6,3	276	6,3	268	6,3	259	6,3	251	6,3	242	6,3	234	6,3	225	8,6	216	8,6	205	8,6	193	8,6	178	8,6							
305	6,6	298	6,6	291	9	284	9	277	9	270	9	263	9	256	9	249	9	242	9	235	11	228	11							
359	9	351	9	342	9	334	9	325	9	317	9	308	11	300	11	291	11	282	11	273	11	264	11							
452	11	441	11	429	11	418	11	407	13,2	396	13,2	385	13,2	374	13,2	363	13,2	352	13,2	341	18	330	18							
519	12,6	506	12,6	493	12,6	480	12,6	467	12,6	454	12,6	441	12,6	428	12,6	415	12,6	402	12,6											
562	11	552	11	541	11	531	11	520	13,2	510	13,2	500	13,2	490	13,2	480	18	470	18	460	18	450	18	440	18	430	18			
1054	23	1036	23	1018	29	1000	29	982	29	964	29	946	29																	

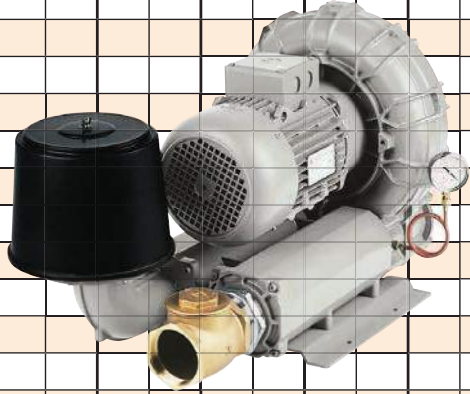

Flow rates refer to air at the suction conditions of 20°C and 1013mbar abs.
Tolerance on flow rate values: ±10%

- CL 40 HS three phase motor: 1,15kW and 1,5kW - single phase motor: 0,9kW and 1,3kW
- CL 420 HS three phase motor: 2,05kW - single phase motor: 1,75kW
- CL 1R3.5 three phase motor: 0,83kW - single phase motor: 0,8kW

12

MAPRO

Aspiratori con motori a 50 Hz (2900 giri/min)

Exhausters with 50 Hz motors (2900 rpm)

Nota / Note:

La maggior parte degli aspiratori per aria è disponibile anche in esecuzione per Zone 1 e 2, 21 e 22 della Direttiva Europea 94/9/CE (ATEX).
Most of the exhauster models for air are also manufactured in conformity to the requirements of the European Directive 94/9/EC (ATEX) for Zones 1 and 2, 21 and 22.

50 Hz

Diagramma portate-depressioni

Flow rate-vacuum diagram

Legend / Legenda

Machine type / Tipo macchina	Motor power (kW) / Potenza motore (kW)
60/1	7.5
7.5	7.5

Key

Machine type / Tipo macchina	Motor power (kW) / Potenza motore (kW)
60/1	7.5
7.5	7.5

Flow rate-vacuum diagram data (approximate values):

Model	Motor Power (kW)	Flow Rate [m³/h]	Inlet Vacuum [hPa = mbar]
10/21	2.2	20	-350
12/21	2.2	40	-350
14/21	2.2	60	-350
17/21	4	20	-450
20/21	4	40	-450
23/21	5.5	60	-450
30/21	5.5	100	-450
36/21	7.5	150	-450
42/21	7.5	200	-450
49/21	9.2	300	-450
2R9	16.5	700	-450
TB7/M	18.5	650	-450
38/1	15	500	-350
18/1	11	450	-350
84/1	15	350	-350
2R8	17.5	300	-350
60/1	7.5	250	-350
72/1	9.2	300	-350
46/1	7.5	200	-350
40/1	5.5	150	-350
80-7 HS	5.5	150	-350
34/1	4	100	-350
52/HS	3	80	-350
28/1	1.5	60	-350
22/01	4	80	-250
60/HS	3	100	-250
185.5	2.2	100	-250
150/1	1.5	80	-250
4/21	0.75	20	-200
220/HS	0.8	20	-200
10/01	1.1	20	-200
7/01	0.37	20	-150
1R3.5	0.55	20	-150
7/01	0.55	20	-150
1R3.5	0.7	20	-150
30-7 HS	0.4	20	-100
3.60/1	0.4	20	-100
20/HS	0.22	20	-50

Portate riferite ad aria a 20°C e alla pressione d'aspirazione; la pressione di mandata è di 1013 mbar abs.
Flow rates refer to air at the suction pressure and 20°C and with discharge pressure of 1013 mbar abs.

Depressione all'aspirazione Inlet vacuum [hPa = mbar]		Salto di temperatura °C - Temperature rise °C																
		-50	-75	-100	-125	-150	-175	-200	-225	-250	-275	-300	-325	-350	-375	-400	-425	-450
Tipo Aspiratore Exhauster Type	CL 20 HS	13																
	CL 30-Z HS	13	20	32														
	CL 3.6/01	11	15	22	30	42												
	CL 4/01	13	18	25	33	43												
	CL 7/01	11	19	29	42	56												
	CL 1R3.5	14	21	29	40	55												
	CL 10/01	14	20	27	36	46	56	66										
	CL 40 HS	8	12	18	25	34	53											
	CL 15/01	12	15	19	25	32	42	56	79									
	CL 50 HS	9	12	17	23	32	43	63										
	CL 18/01	11	14	19	25	32	40	51	62	75								
	CL 1R5.5	10	14	20	27	36	48	63	84									
	CL 60 HS	10	12	15	20	27	36	49	75									
	CL 28/1	7	9	13	18	24	32	41	51	62	76	94						
	CL 22/01	13	16	21	27	35	45	57	70	85								
	CL 34/1	8	11	14	18	23	29	37	47	58	70	84						
	CL 40/1	10	13	16	20	25	30	37	44	52	62	74	92					
	CL 80-Z HS	8	11	15	18	24	30	38	49	61	75	95						
	CL 46/1	7	10	13	17	22	27	34	42	51	60	70	81	95				
	CL 60/1	10	13	17	22	28	34	41	48	56	65	76	90					
	CL 72/1	11	14	17	21	25	30	35	41	49	59	72	95					
	CL 1R9	15	18	22	27	32	38	44	52	61	73	88						
	CL 84/1	12	14	16	19	22	26	30	36	42	51	62	76	95				
	CL 98/1	12	15	19	23	28	34	40	47	54	62	72	84	99				
	TBT/M	14	16	19	23	28	33	40	47	55	64	74	86	100				
	CL 4/21	15	19	24	31	38	46	55	65									
	CL 7/21	12	14	17	21	25	30	35	41	48	57							
	CL 220 HS	7	10	14	18	23	29	38	51									
	CL 10/21	10	13	17	22	27	33	40	47	56	65	74	85					
	CL 12/21	7	9	12	15	18	21	25	28	32	37	42	47	52	58	65		
	CL 420 HS	10	12	14	17	21	27	33	41	50	60	72						
	CL 14/21	9	11	14	17	20	24	28	32	37	42	47	53	59	65	73	81	
	CL 17/21	10	12	15	18	22	26	30	34	39	44	49	55	61	68	75	84	93
	CL 520 HS	9	11	13	17	20	24	30	35	43	50	60	73	86				
	CL 20/21	9	11	14	17	21	25	29	34	39	44	50	56	63	70	78	87	96
CL 23/21	9	12	15	18	22	26	30	34	39	44	49	55	61	68	75	83	92	
CL 720 HS	13	15	17	20	23	27	32	37	42	49	56	66	75	86	99			
CL 30/21	10	13	16	19	23	27	31	36	41	47	54	60	67	74	82	90	99	
CL 36/21	13	15	18	21	24	28	32	38	44	50	57	65	73	81	90	99		
CL 42/21	13	16	19	22	25	29	33	38	44	50	57	64	72	81	90	100		
CL 2R8	13	17	21	26	31	36	41	47	53	60	68	79	94					
CL 49/21	13	16	19	22	25	29	33	38	44	51	58	64	72	80	89	99		
CL 2R9	16	19	22	26	30	34	38	43	49	55	62	70	80	92				

Tolleranza: ± 5 °C - Tolerance: ± 5 °C

Depressione all'aspirazione Inlet vacuum [hPa = mbar]		Rumorosità dB(A) ad 1m Sound level dB(A) at 1m							
		-50	-100	-150	-200	-250	-300	-325	-350
Tipo Aspiratore Exhauster Type	CL 20 HS	67							
	CL 30-Z HS	68	72						
	CL 3.6/01	69	70	70					
	CL 4/01	71	72	73					
	CL 7/01	73	74	74					
	CL 1R3.5	69	70	70					
	CL 10/01	71	71	71	72				
	CL 40 HS	69	71	72					
	CL 15/01	71	72	72	73				
	CL 50 HS	71	72	73	74				
	CL 18/01	72	72	73	73	74			
	CL 1R5.5	71	71	72	73				
	CL 60 HS	73	74	75	76				
	CL 28/1	71	71	72	73	73	73		
	CL 22/01	73	73	74	74	75			
	CL 34/1	73	74	74	75	75	76		
	CL 40/1	75	76	77	78	78	78	77	
	CL 80-Z HS	73	73	73	73	73	74		
	CL 46/1	77	78	78	78	79	80	80	80
	CL 60/1	79	79	80	80	80	81	81	
	CL 72/1	78	79	81	81	81	82	82	
	CL 1R9	75	76	78	79	80	81		
	CL 84/1	80	81	82	82	82	83	84	84
	CL 98/1	79	79	80	81	81	82	82	82
	TBT/M	79	79	80	81	81	82	82	82

Depressione all'aspirazione Inlet vacuum [hPa = mbar]		Rumorosità dB(A) ad 1m Sound level dB(A) at 1m							
		-100	-150	-200	-250	-300	-350	-400	-450
Tipo Aspiratore Exhauster Type	CL 4/21	71	72	72					
	CL 7/21	72	72	73	73				
	CL 220 HS	62	62	63					
	CL 10/21	72	72	73	73	74			
	CL 12/21	70	71	71	71	71	72	72	
	CL 420 HS	70	70	71	71	71			
	CL 14/21	70	70	70	70	70	71	71	
	CL 17/21	72	73	74	74	75	76	77	78
	CL 520 HS	72	72	73	73	74	74		
	CL 20/21	71	72	72	73	74	74	74	74
	CL 23/21	76	77	78	79	81	81	82	82
	CL 720 HS	73	74	75	75	75	76	76	
	CL 30/21	75	76	76	77	77	77	78	78
	CL 36/21	77	77	77	77	78	78	78	
	CL 42/21	80	80	81	81	82	83	83	
	CL 2R8	75	76	76	76	76	77		
	CL 49/21	79	79	79	79	79	79	80	
CL 2R9	80	80	81	81	82	82	82		

La rumorosità è intesa come livello di pressione sonora Lp, misurato in campo libero, in accordo alla Norma EN ISO 2151.
Tolleranza sui valori di rumorosità: ± 2 dB(A).

The noise level is intended as sound pressure level (SPL), measured in free field, in accordance with the Standard EN ISO 2151.
Tolerance on sound level values: ± 2 dB(A).

(2900 giri/min)
(2900 rpm)



Nota / Note:

La maggior parte degli aspiratori per aria è disponibile anche in esecuzione per Zone 1 e 2, 21 e 22 della Direttiva Europea 94/9/CE (ATEX).

Most of the exhauster models for air are also manufactured in conformity to the requirements of the European Directive 94/9/EC (ATEX) for Zones 1 and 2, 21 and 22.

-325		-350		-375		-400		-425		-450		-475		-500		-525		-550		-575		-600		-625		-650	
m³/h	kW	m³/h	kW	m³/h	kW	m³/h	kW	m³/h	kW	m³/h	kW	m³/h	kW	m³/h	kW	m³/h	kW	m³/h	kW	m³/h	kW	m³/h	kW	m³/h	kW	m³/h	kW
170	5,5																										
226	7,5	200	7,5																								
260	7,5																										
286	9,2																										
455	15	375	15																								
574	15,0	505	15,0																								
690	18,5	640	18,5																								
6	2,2																										
33	2,2	27	2,2	21	2,2	15	2,2																				
60	2,2	53	2,2	46	2,2	39	2,2	33	2,2																		
92	3	84	3	75	3	67	3	58	4	50	4																
83	3	60	3																								
114	3	104	3	94	4	84	4	74	4	64	4																
143	4	132	4	121	4	111	4	100	5,5	90	5,5																
152	4,3	133	4,3	113	5,5	90	5,5																				
200	5,5	189	5,5	177	5,5	165	5,5	150	5,5	132	5,5																
241	5,5	226	5,5	211	7,5	195	7,5	178	7,5																		
310	7,5	290	7,5	268	7,5	245	7,5	215	7,5																		
330	7,5	305	7,5																								
384	7,5	365	7,5	344	9,2	328	9,2	300	9,2																		
793	16,5	757	16,5	710	16,5																						

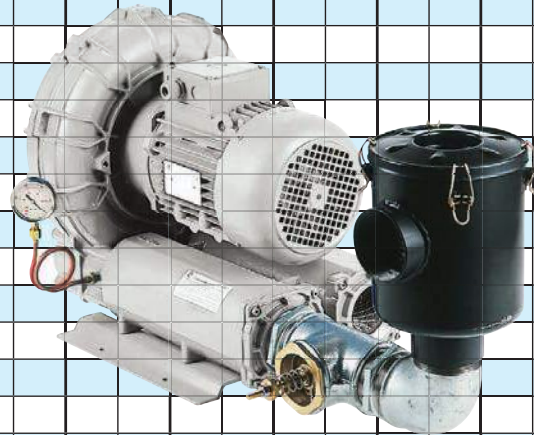

Flow rates refer to air at the suction pressure and 20°C and with discharge pressure of 1013mbar abs.

Tolerance on flow rate values: ±10%

(●) CL 40 HS three phase motor: 0,9kW - single phase motor: 0,8kW

(●) CL 420 HS three phase motor: 1,6kW - single phase motor: 1,5kW

16

MAPRO

Aspiratori con motori a 60 Hz (3500 giri/min)

Exhausters with 60 Hz motors (3500 rpm)

Nota / Note:

La maggior parte degli aspiratori per aria è disponibile anche in esecuzione per Zone 1 e 2, 21 e 22 della Direttiva Europea 94/9/CE (ATEX).
Most of the exhauster models for air are also manufactured in conformity to the requirements of the European Directive 94/9/CE (ATEX) for Zones 1 and 2, 21 and 22.

Diagramma portate-depressioni

Flow rate-vacuum diagram

Legend / Key

Line Style	Machine type	Motor power (kW)
60/1	↔	↔
11/1	↔	↔

Portate / Flow rate → [m³/h]

Depressione all'aspirazione [hPa = mbar] / **Inlet vacuum [hPa = mbar]**

Portate riferite ad aria a 20°C e alla pressione d'aspirazione; la pressione di mandata è di 1013 mbar abs.
Flow rates refer to air at the suction pressure and 20°C and with discharge pressure of 1013 mbar abs.

		Salto di temperatura °C - Temperature rise °C																
Depressione all'aspirazione Inlet vacuum [hPa = mbar]		-50	-75	-100	-125	-150	-175	-200	-225	-250	-275	-300	-325	-350	-375	-400	-425	-450
Tipo Aspiratore Exhauster Type	CL 20 HS	15	23															
	CL 30-Z HS	9	13	19	30	47												
	CL 3.6/01	11	15	21	28	38												
	CL 4/01	14	18	25	32	40	50											
	CL 7/01	13	19	25	32	41	54	71										
	CL 1R3.5	15	21	28	37	49												
	CL 10/01	17	22	27	34	42	50	60	70									
	CL 40 HS	9	12	17	22	28	39											
	CL 15/01	13	15	18	22	27	36	46	60	82								
	CL 50 HS	11	14	17	21	27	33	42	54									
	CL 18/01	14	17	22	27	33	40	48	58	71	90							
	CL 1R5.5	14	17	21	27	34	42	51	62	75								
	CL 60 HS	12	15	18	22	26	32	38	46	56	67	80						
	CL 28/1	8	11	15	19	24	30	36	46	57	71	90						
	CL 22/01	15	19	24	29	35	43	53	64	76	94							
	CL 34/1	8	11	14	18	23	28	35	42	50	60	74						
	CL 40/1	11	13	16	20	24	29	35	41	48	55	64	75	88				
	CL 80-Z HS	10	13	15	18	22	27	33	40	49	59	70	84	98				
	CL 46/1	8	11	14	18	22	27	32	39	46	55	65	76	90				
	CL 60/1	12	14	16	19	23	28	33	40	47	55	65	76	90				
	CL 72/1	14	17	20	24	28	32	37	42	49	58	70	90					
	CL 1R9	18	21	25	29	34	39	45	52	60	69	80	94					
	CL 84/1	16	17	19	22	25	28	32	37	43	51	60	73	90				
	CL 98/1	18	20	23	26	30	35	40	46	53	60	70	81	95				
	TBT/M	17	19	21	24	28	33	38	44	51	59	67	76	88				
	CL 4/21	17	21	26	32	38	45	53	61	71								
	CL 7/21	13	15	18	22	26	30	35	40	46	53							
	CL 220 HS	9	11	14	18	23	28	34	41	49								
	CL 10/21	14	17	20	23	27	32	37	43	51	60	69	80					
	CL 12/21	10	11	13	15	17	20	23	27	31	35	40	45	50	56	62	69	77
	CL 420 HS	12	14	16	19	23	27	33	39	47	54	64	74	85				
	CL 14/21	12	13	15	17	19	22	25	29	33	37	41	45	50	55	61	68	75
	CL 17/21	10	12	15	18	22	26	30	34	38	43	48	54	60	66	73	81	89
	CL 520 HS	11	13	15	17	20	24	27	31	36	42	48	55	64	75	87		
CL 20/21	12	14	17	20	24	28	32	36	41	47	52	58	64	70	76	85	94	
CL 23/21	12	15	18	21	24	28	32	36	40	45	50	55	60	66	73	81	90	
CL 720 HS	17	19	20	23	25	28	32	35	40	44	50	55	62	69	79	89		
CL 30/21	12	15	18	21	24	27	31	35	40	45	51	57	64	71	79	87	95	
CL 36/21	18	20	22	25	28	32	36	41	46	52	58	64	70	77	84	91	100	
CL 42/21	18	20	22	25	28	31	34	38	43	48	54	60	67	75	83	92	101	
CL 2R8	19	22	25	29	33	37	42	47	52	58	65	73	83	96				
CL 49/21	19	22	25	28	32	36	40	44	49	54	59	65	71	78	85	93	102	
CL 2R9	20	23	26	29	32	36	40	44	49	54	60	67	74	82	93			

Tolleranza: ± 5 °C - Tolerance: ± 5 °C

		Rumorosità dB(A) ad 1m Sound level dB(A) at 1m							
Depressione all'aspirazione Inlet vacuum [hPa = mbar]		-50	-100	-150	-200	-250	-300	-325	-350
Tipo Aspiratore Exhauster Type	CL 20 HS	68							
	CL 30-Z HS	68	72	74					
	CL 3.6/01	71	72	73					
	CL 4/01	74	75	76					
	CL 7/01	76	77	78	79				
	CL 1R3.5	69	70	71					
	CL 10/01	73	73	73	74				
	CL 40 HS	70	72	72					
	CL 15/01	73	74	74	76	76			
	CL 50 HS	71	72	73	74				
	CL 18/01	74	75	75	76	77			
	CL 1R5.5	72	72	73	73	74			
	CL 60 HS	75	75	76	76	77	78		
	CL 28/1	76	77	78	79	79	79		
	CL 22/01	75	75	76	76	77			
	CL 34/1	76	76	77	78	78	79		
	CL 40/1	79	80	81	82	82	82	82	81
	CL 80-Z HS	76	76	76	76	76	77	77	77
	CL 46/1	80	80	81	82	83	83	84	84
	CL 60/1	81	81	82	83	83	84	84	84
	CL 72/1	82	82	83	84	84	85	86	
	CL 1R9	77	78	79	80	81	82		
	CL 84/1	82	82	83	84	85	85	86	86
CL 98/1	82	83	83	84	85	86	86	86	
TBT/M	80	81	82	83	83	84	84	84	

		Rumorosità dB(A) ad 1m Sound level dB(A) at 1m							
Depressione all'aspirazione Inlet vacuum [hPa = mbar]		-100	-150	-200	-250	-300	-350	-400	-450
Tipo Aspiratore Exhauster Type	CL 4/21	73	73	74	75				
	CL 7/21	73	73	74	75				
	CL 220 HS	68	69	69	69				
	CL 10/21	74	74	75	76	76			
	CL 12/21	75	76	76	77	77	77	78	78
	CL 420 HS	73	73	73	73	73	74		
	CL 14/21	75	76	77	77	77	77	77	78
	CL 17/21	73	74	75	75	76	78	79	79
	CL 520 HS	75	75	75	75	75	76	76	
	CL 20/21	74	74	75	75	76	76	76	76
	CL 23/21	80	80	81	81	82	82	82	83
	CL 720 HS	77	78	78	78	79	79	79	
	CL 30/21	80	81	81	81	82	82	82	83
	CL 36/21	82	82	82	82	83	83	83	83
	CL 42/21	81	82	82	83	84	84	85	85
	CL 2R8	77	78	78	78	79	80		
	CL 49/21	83	83	83	83	84	84	85	85
CL 2R9	80	81	81	82	83	83	83		

La rumorosità è intesa come livello di pressione sonora Lp, misurato in campo libero, in accordo alla Norma EN ISO 2151.
Tolleranza sui valori di rumorosità: ± 2 dB(A).

The noise level is intended as sound pressure level (SPL), measured in free field, in accordance with the Standard EN ISO 2151.
Tolerance on sound level values: ± 2 dB(A).

CL 3.6/01 - CL 4/01 - CL 7/01 - CL 10/01 - CL 15/01 - CL 18/01 - CL 22/01

Soffianti
Blowers

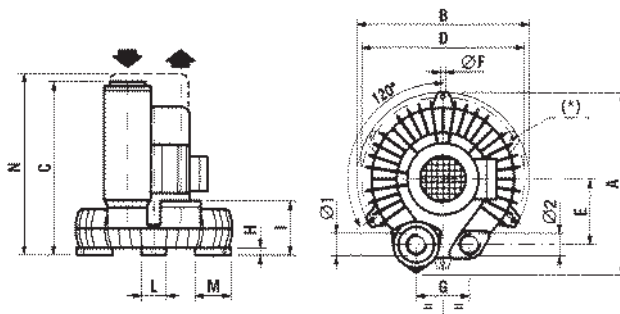

(*) posizione piedi solo per CL 3.6/01 e CL 4/01
(* feet position for CL 3.6/01 and CL 4/01 only)

Aspiratori
Exhausters

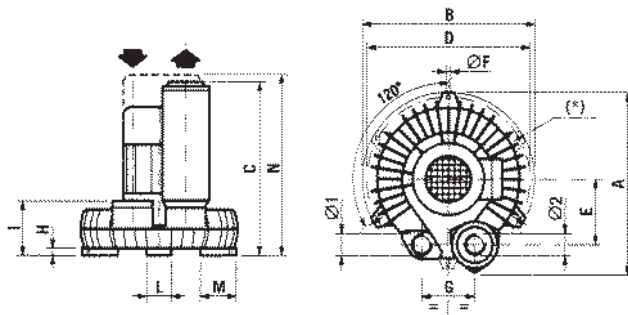
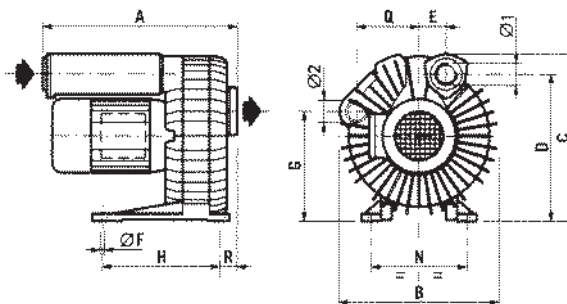

FIG. 1

CL 4/21 - CL 7/21 - CL 10/21

Soffianti
Blowers



Aspiratori
Exhausters

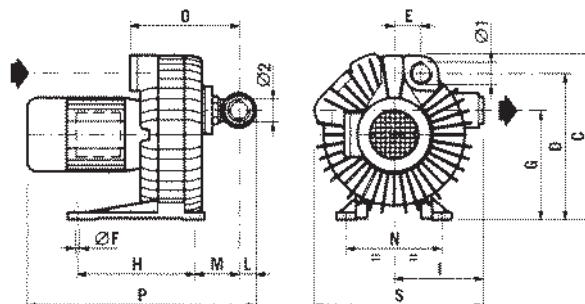
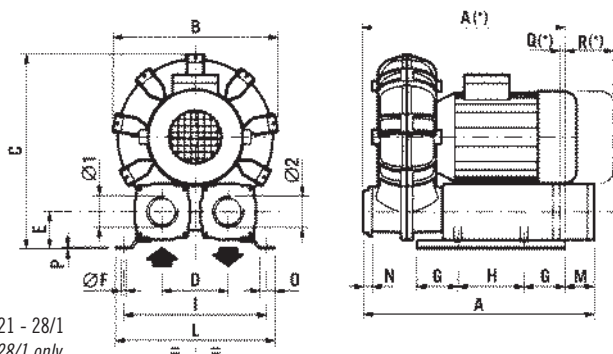
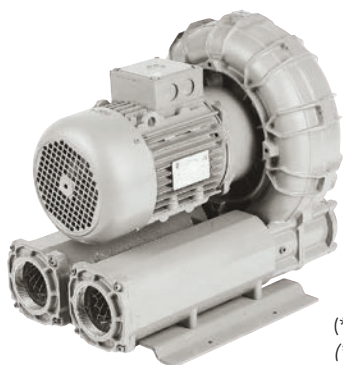

FIG. 2

CL 12/21 - CL 14/21 - CL 17/21 - CL 20/21 - CL 23/21 - CL 30/21 - CL 36/21 - CL 42/21 - CL 49/21
CL 28/1 - CL 34/1 - CL 40/1 - CL 46/1 - CL 60/1 - CL 72/1 - CL 84/1 - CL 98/1



(*) solo per CL 12/21 - 14/21 - 28/1
(* for CL 12/21 - 14/21 - 28/1 only)

FIG. 3

Tipo macchina <i>Machine Type</i>	Figura di riferimento <i>Reference figure</i>	A	B	C	D	E	ØF	G	H	I	L	M	N	O	P	Q	R	S	Attacchi ("gas) <i>Connections ("gas)</i>		Peso <i>Weight</i> [kg]	
																			aspir. <i>inlet</i> Ø1	mand. <i>outlet</i> Ø2		
CL 3.6/01	Fig. 1	290	310	277	290	115	10	67	16	91	55	70								1"	1"	11
CL 4/01	Fig. 1	290	310	277	290	115	10	67	16	91	55	70	315							1"	1"	12
CL 7/01	Fig. 1	340	360	343	340	125	10	110	16	110	55	70								1" 1/4	1" 1/4	17
CL 10/01	Fig. 1	405	390	383	370	145	10	119	16	118	55	70								1" 1/2	1" 1/2	23
CL 15/01	Fig. 1	447	425	395	405	170	10	130	16	130	55	70								2"	2"	30
CL 18/01	Fig. 1	505	450	486	430	202	10	148	16	166	55	70								2" 1/2	2" 1/2	43
CL 22/01	Fig. 1	535	485	502	465	216	10	170	16	182	55	70								2" 1/2	2" 1/2	52
CL 28/1	Fig. 3	446	370	445	140	85	9	100	160	310	350	-	21	35	5	1	45			2" 1/2	2" 1/2	48
CL 34/1	Fig. 3	560	400	470	160	90	9	100	160	347	387	70	22	35	5					2" 1/2	2" 1/2	66
CL 40/1	Fig. 3	550	416	490	160	90	9	100	160	347	387	70	22	35	5					3"	3"	77
CL 46/1	Fig. 3	680	440	520	180	97	11	60	330	400	450	120	22	45	5					3"	3"	93
CL 60/1	Fig. 3	700	440	520	180	97	11	60	330	400	450	120	22	45	5					3"	3"	103
CL 72/1	Fig. 3	735	466	560	180	107	11	60	330	420	470	185	17	45	5					4"	4"	102
CL 84/1	Fig. 3	765	505	615	180	107	11	60	330	420	470	185	17	45	5					4"	4"	112
CL 98/1	Fig. 3	750	532	640	180	107	11	60	330	420	470	185	17	45	5					4"	4"	120
CL 4/21	Fig. 2	311	275	284	254	33	9	196	160	230	35	65	140	163	420	106	27	368		1"	1"	17
CL 7/21	Fig. 2	403	322	337	298	55	12	222	240	182	35	98	195	230	480	127	36	345		1" 1/4	1" 1/4	26
CL 10/21	Fig. 2	452	350	380	329	60	12	244	240	200	55	115	205	257	585	145	45	375		1" 1/2	1" 1/2	36
CL 12/21	Fig. 3	440	350	420	130	79	9	100	160	288	328	-	19	35	5	6	40			1" 1/2	1" 1/2	42
CL 14/21	Fig. 3	445	370	440	130	79	9	100	160	288	328	-	19	35	5	6	40			2"	2"	42
CL 17/21	Fig. 3	560	400	470	160	90	9	100	160	347	387	70	22	35	5					2" 1/2	2" 1/2	54
CL 20/21	Fig. 3	550	416	490	160	90	9	100	160	347	387	70	22	35	5					2" 1/2	2" 1/2	66
CL 23/21	Fig. 3	590	440	515	160	90	9	100	160	347	387	70	22	35	5					2" 1/2	2" 1/2	82
CL 30/21	Fig. 3	700	440	520	180	97	11	60	330	400	450	120	22	45	5					3"	3"	88
CL 36/21	Fig. 3	675	466	550	180	97	11	60	330	400	450	120	22	45	5					3"	3"	90
CL 42/21	Fig. 3	765	505	615	180	107	11	60	330	420	470	185	17	45	5					3"	3"	106
CL 49/21	Fig. 3	750	532	640	180	107	11	60	330	420	470	185	17	45	5					4"	4"	112
TBT/M	Fig. 4	725	556	1120	220	835	16	25	392	300	400	65	140	50	8	100	1325			4"	4"	220

Dimensioni [mm]

I pesi sono quelli delle macchine con motore di potenza maggiore

Dimensions [mm]

Weights shown are for the machines fitted with the largest motor power

TBT / M

FIG. 4

Soffianti
Blowers

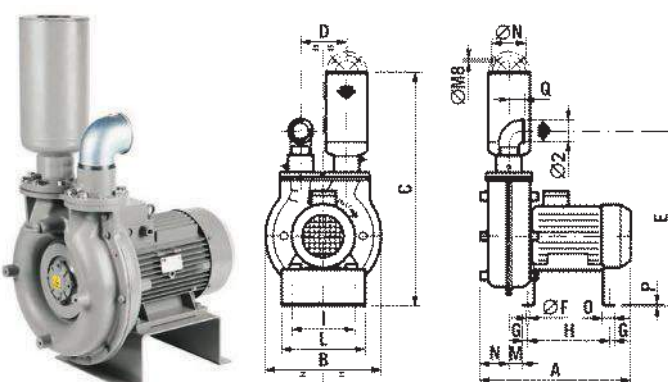

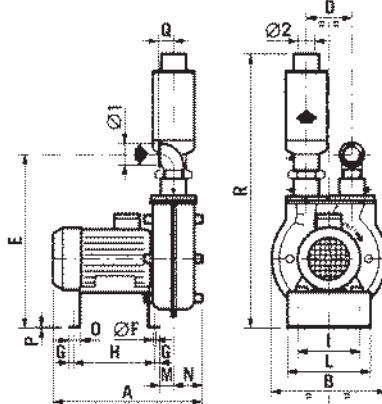

Aspiratori
Exhausters



CL 20 HS - CL 30-Z HS - CL 40 HS - CL 50 HS - CL 60 HS - CL 80-Z HS - CL 1R3.5 - CL 1R5.5

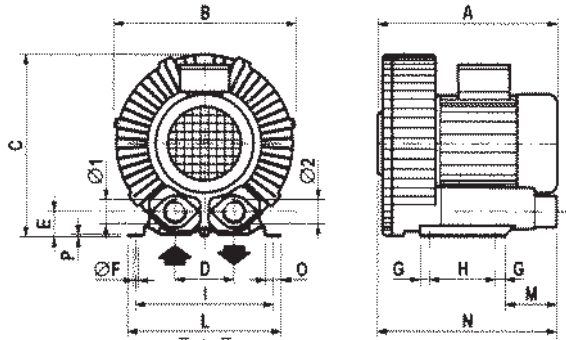
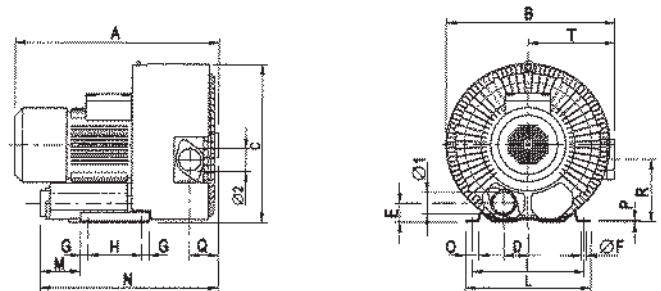

FIG. 5

CL 220 HS - CL 420 HS - CL 520 HS - CL 720 HS (solo/only 3kW - 4,3kW) - CL 2R8 (solo/only 7,5kW)

Soffianti
Blowers



Aspiratori
Exhausters

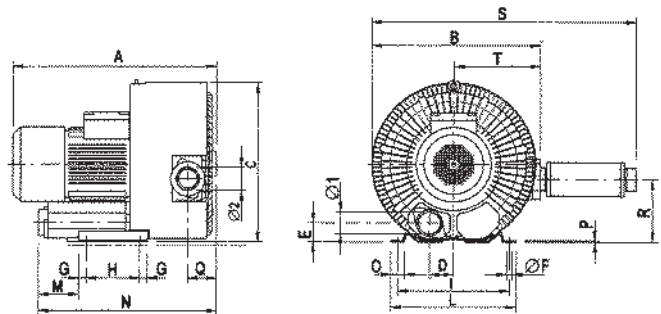
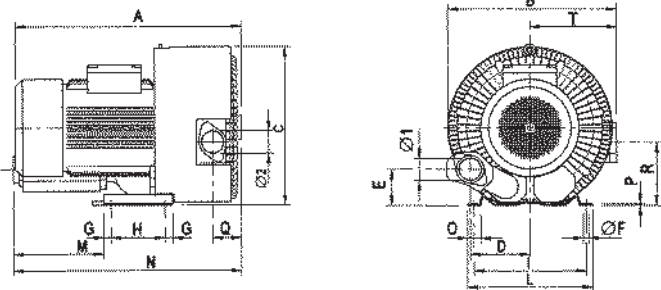

FIG. 6

CL 720 HS (solo/only 5,5kW - 7,5kW) - CL 2R8 (solo/only 11kW)

Soffianti
Blowers



Aspiratori
Exhausters

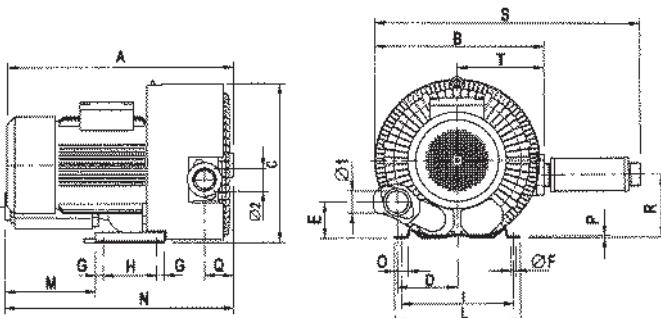

FIG. 7

Tipo macchina <i>Machine Type</i>	Figura di riferimento <i>Reference figure</i>	A	B	C	D	E	ØF	G	H	I	L	M	N	O	P	Q	R	S	T	Attacchi ("gas") <i>Connections ("gas")</i>		Peso <i>Weight</i> [kg]	
																				aspir. <i>inlet</i> Ø1	mand. <i>outlet</i> Ø2		
CL 20 HS	Fig. 5	255	228	235	90	35	10	12	76	190	212	73	218	40	13						1"	1"	10,5
CL 30-Z HS	Fig. 5	255	246	247	90	39	10	12,5	83	205	219	54	228	20	2,5						1" 1/4	1" 1/4	13,5
CL 1R3.5	Fig. 5	260	275	275	93	41	10	12,5	83	205	230	69,5	234	20	2,5						1" 1/4	1" 1/4	14
CL 40 HS	Fig. 5	270	286	305	115	45	12	17,5	95	225	255	48	240	30	3						1" 1/2	1" 1/2	18
CL 50 HS	Fig. 5	315	333	335	120	48	14	20	115	260	295	125	345	30	4						2"	2"	26
CL 1R5.5	Fig. 5	354	360	365	122	56	13	20	140	284	325	45	318	30	4,5						2"	2"	28
CL 60 HS	Fig. 5	395	382	385	125	45	15	20	140	290	325	110	380	30	4,5						2"	2"	41,5
CL 80-Z HS	Fig. 5	477	451	509	152	65	15	23,5	170	356	394	114	462	35	6						2" 1/2	2" 1/2	68
CL 1R9	Fig. 8	611	550	569	103,5	92	15	89	533	360	415	17	644	70	21						4"	4"	126
CL 220 HS	Fig. 6	320	315	270	45	39	10	12,5	83	205	230	63	289	25	2,5	53	106	540	173		1" 1/4	1" 1/4	14
CL 420 HS	Fig. 6	400	355	315	58	46	12	16,5	95	225	256	51	314	30	3	45	154	570	195		1" 1/2	1" 1/2	27
CL 520 HS	Fig. 6	500	410	371	60	48	14	20	115	260	295	97	404	40	4	56	144	645	224		2"	2"	43
CL 720 HS (3-4,3 kW)	Fig. 6	532	435	424	63	50	14	20	140	290	325	86	451	48	4,5	76	164	685	257		2"	2"	53
CL 720 HS (5,5-7,5 kW)	Fig. 7	590	435	424	154	94	14	20	140	290	325	225	595	48	4,5	76	164	685	257		2"	2"	77
CL 2R8 (7,5 kW)	Fig. 6	594	549	490	76	65	15	23,5	170	356	394	116	551	45	6	89	199	795	299		2" 1/2	2" 1/2	85
CL 2R8 (11 kW)	Fig. 7	594	549	490	172	105	15	23,5	170	356	394	349	760	45	6	89	199	795	299		2" 1/2	2" 1/2	103
CL 2R9	Fig. 9	812	658	608	103,5	92	15	230	533	360	415		786	70	21	113	236	1127	350		4"	4"	211

Dimensioni [mm]

I pesi sono quelli delle macchine con motore di potenza maggiore

Dimensions [mm]

Weights shown are for the machines fitted with the largest motor power

CL 1R9

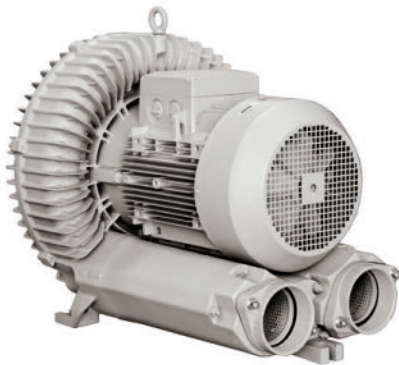
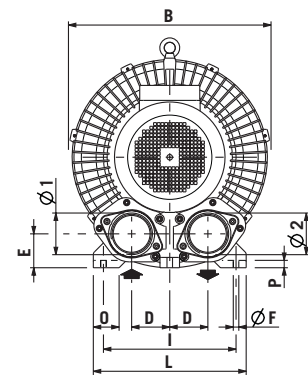
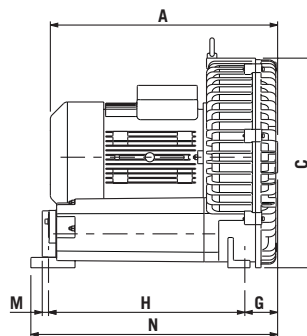

FIG. 8



CL 2R9

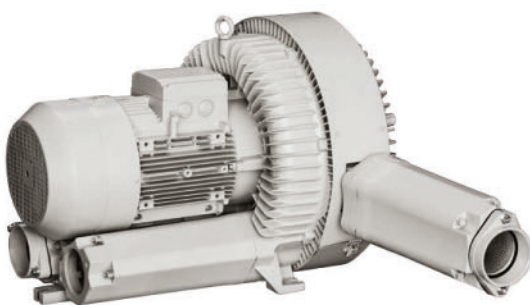
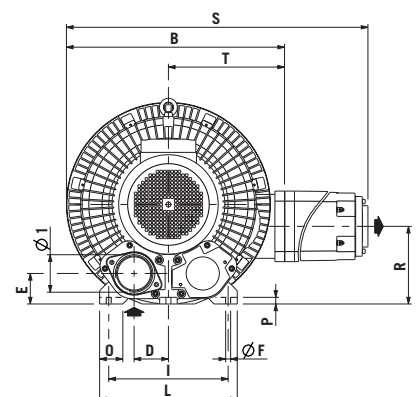
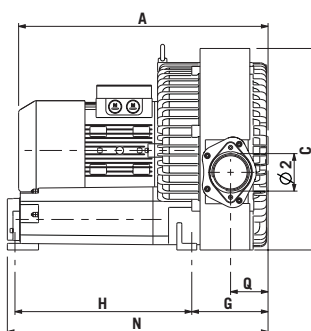

FIG. 9



Soffianti e aspiratori per aria - Esecuzioni speciali

Blowers and exhausters for air - Special versions



Serie BD

Azionamento a mezzo cinghie e pulegge

BD Series

Belt drive version



Nota / Note:

Disponibili anche in esecuzione per Zone 1 e 2, 21 e 22 della Direttiva Europea 94/9/CE (ATEX).

Also manufactured in conformity to the requirements of the European Directive 94/9/EC (ATEX) for Zones 1 and 2, 21 and 22.



Serie V

Esecuzione monoblocco ad asse verticale

V Series

Compact version in vertical axis



Nota / Note:

Disponibili anche in esecuzione per Zone 1 e 2, 21 e 22 della Direttiva Europea 94/9/CE (ATEX).

Also manufactured in conformity to the requirements of the European Directive 94/9/EC (ATEX) for Zones 1 and 2, 21 and 22.



Serie VL

Esecuzione ad asse verticale con lanternotto e giunto d'accoppiamento a motore

VL Series

Machine in vertical axis, with hub and flexible coupling between machine and motor



Nota / Note:

Disponibili anche in esecuzione per Zone 1 e 2, 21 e 22 della Direttiva Europea 94/9/CE (ATEX).

Also manufactured in conformity to the requirements of the European Directive 94/9/EC (ATEX) for Zones 1 and 2, 21 and 22.



Serie HC

Esecuzione ad asse orizzontale con giunto d'accoppiamento a motore

HC Series

Machine in horizontal axis, coupled to the motor via a flexible shaft coupling



Nota / Note:

Disponibili anche in esecuzione per Zone 1 e 2, 21 e 22 della Direttiva Europea 94/9/CE (ATEX).

Also manufactured in conformity to the requirements of the European Directive 94/9/EC (ATEX) for Zones 1 and 2, 21 and 22.

In addition to the above listed versions, it is possible to supply other special units with motor direct coupled via a flexible shaft coupling or belt driven.

Filtri di linea per aspiratori In-line filters for exhausters										
Tipo filtro Filter type	Tipo macchina Machine type	Ø A1	Ø A2	Ø B	C	D	E	F	Peso Weight [kg]	Tipo cartuccia filtrante Filter cartridge type
		("gas)		[mm]						
IF4AH	CL 3.6/01	1"	1"	133	139	355	90	78	1,7	FE4...(•)
	CL 4/01					255				
	CL 20 HS									
IF5AH	CL 30-Z HS	1" 1/4	1" 1/4	170	205	225	140	96	2,7	FE5...(•)
	CL 1R3.5									
	CL 220 HS									
IF6AH	CL 40 HS	1" 1/2	1" 1/2	170	239	240	175	100	3,1	FE6...(•)
	CL 12/21					260				
	CL 420 HS					340				
IF7AH	CL 50 HS	2"	2"	200	314	260	180	114	5,4	FE7...(•)
	CL 1R5.5					360				
	CL 60 HS									
	CL 14/21									
IF8AH	CL 28/1	2" 1/2	2" 1/2	200	324	320	190	114	6,2	FE8...(•)
	CL 80-Z HS					290				
IF8AHR7	CL 520 HS	2" 1/2	2"	200	324	385	190	114	6,8	FE8...(•)
IF10AHR7	CL 720 HS (3-4,3 kW)	3"	2"	200	334	390	200	114	7,6	FE10...(•)
	CL 720 HS (5,5-7,5 kW)					340				
IF10AHR8	CL 2R8	3"	2" 1/2	200	334	340	200	114	7,5	FE10...(•)
IF16AH	CL 1R9	4"	4"	307	427	450	290	165	12	FE16...(•)
	CL 2R9									
IF4AG	CL 4/21	1"	1"	133	139	155	90	78	1,5	FE4...(•)
IF5AG	CL 7/01	1" 1/4	1" 1/4	170	205	185	140	96	2,7	FE5...(•)
	CL 7/21									
IF6AG	CL 10/01	1" 1/2	1" 1/2	170	239	195	175	100	3,1	FE6...(•)
	CL 10/21									
IF7AG	CL 15/01	2"	2"	200	314	225	180	114	5,7	FE7...(•)
IF8AG	CL 18/01	2" 1/2	2" 1/2	200	324	240	190	114	6,4	FE8...(•)
	CL 22/01									
	CL 17/21									
	CL 20/21									
	CL 23/21									
	CL 34/1									
IF10AG	CL 30/21	3"	3"	200	334	250	200	114	7,6	FE10...(•)
	CL 36/21									
	CL 42/21									
	CL 40/1									
	CL 46/1									
	CL 60/1									
IF16AG	CL 49/21	4"	4"	307	427	335	290	165	12,2	FE16...(•)
	CL 72/1									
	CL 84/1									
	CL 98/1									
	TBT/M									

IF4AH - IF5AH
IF6AH - IF7AH
IF8AH - IF8AHR7
IF10AHR7 - IF10AHR8
IF16AH

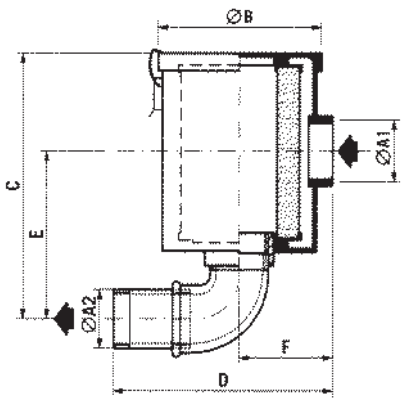

IF4AG - IF5AG
IF6AG - IF7AG
IF8AG - IF10AG
IF16AG

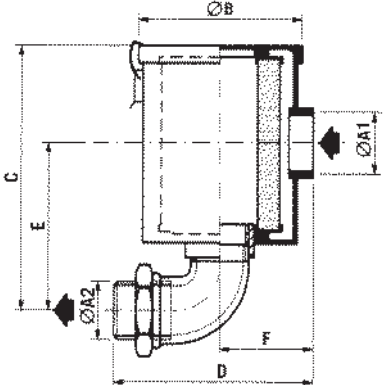

- (•) Le cartucce filtranti sono disponibili nelle versioni:
- FE... C in carta trattata
 - FE... P in poliestere
 - FE... A in poliestere antistatico
 - FE... I in acciaio inox

- (•) The filter cartridges are available made of the following materials:
- FE... C resin treated paper
 - FE... P polyester
 - FE... A antistatic polyester
 - FE... I stainless steel

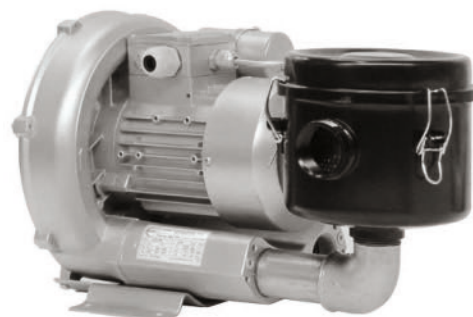

Filtri a cartuccia per soffianti Filters for blowers									
Tipo filtro Filter type	Tipo macchina Machine type	Ø A ("gas)	Ø B [mm]	C [mm]	D [mm]	E [mm]	Peso Weight [kg]	Tipo cartuccia Cartridge type	
F4	CL 3.6/01	1"	95	99	12	100	0,4	C4...(●)	
	CL 4/01								
F5	CL 7/01	1" 1/4	150	106	15	87	0,9	C6...(●)	
F6	CL 10/01	1" 1/2	150	106	15	87	0,9	C6...(●)	
F7	CL 15/01	2"	190	167	18	145	1,5	C8...(●)	
F8	CL 18/01	2" 1/2	190	167	18	145	1,6	C8...(●)	
	CL 22/01								
F4NG	CL 20 HS	1"	95	139	175	100	0,7	C4...(●)	
F5NG	CL 30-Z HS	1" 1/4	150	153	205	87	1,4	C6...(●)	
	CL 1R3.5								
	CL 220 HS								
F6NG	CL 40 HS	1" 1/2	150	158	235	87	1,5	C6...(●)	
F7NG	CL 50 HS	2"	190	227	238	145	2,5	C8...(●)	
	CL 1R5.5								
	CL 60 HS								
F7NGR	CL 420 HS	1" 1/2	190	224	330	145	2,5	C8...(●)	
F8NGR	CL 520 HS	2"	190	235	340	145	3,3	C8...(●)	
F10NGR7	CL 720 HS (3-4,3 kW)	2"	250	304	380	190	4,4	C10...(●)	
	CL 720 HS (5,5-7,5 kW)								280
F10NGR8	CL 80-Z HS	2" 1/2	250	307	305	190	4,6	C10...(●)	
	CL 2R8								
F14NG	CL 1R9	4"	378	395	460	298	10	C14...(●)	
	CL 2R9								
F4G	CL 4/21	1"	95	139	100	100	0,5	C4...(●)	
F5G	CL 7/21	1" 1/4	150	153	135	87	1,1	C6...(●)	
F6G	CL 10/21	1" 1/2	150	158	140	87	1,1	C6...(●)	
F8/1G	CL 12/21	-	190	241	261	145	2,2	C8...(●)	
	CL 14/21			244	270				
	CL 17/21			241	271				2
	CL 20/21			244	270				2,2
	CL 23/21								
	CL 28/1								
F10/1G	CL 30/21	-	250	304	326	190	2,4	C10...(●)	
	CL 36/21			307	300				
	CL 40/1			304	326				
	CL 46/1								
F14G	CL 42/21	-	378	411	330	298	7,5	C14...(●)	
	CL 49/21								
	CL 72/1								
	CL 84/1								
F14	TBT/M	194	378	27	-	298	5,4	C14...(●)	

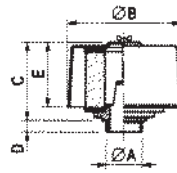

F4 - F5 - F6
F7 - F8

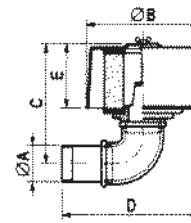

F4NG - F5NG - F6NG
F7NG - F14NG - F7NGR
F8NGR - F10NGR7
F10NGR8

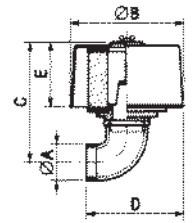

F4G - F5G - F6G

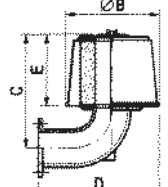

F8/1G - F10/1G

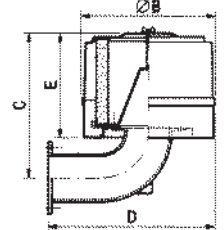

F14G

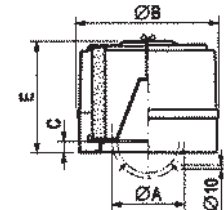

F14



(●) Le cartucce filtranti sono disponibili nelle versioni:

- C... C in carta trattata
- C... P in poliestere
- C... A in poliestere antistatico
- C... I in acciaio inox

(●) The cartridges are available made of the following materials:

- C... C resin treated paper
- C... P polyester
- C... A antistatic polyester
- C... I stainless steel



Rete filtrante e coperchio in acciaio inox (AISI 304)
Manicotto filettato in Nylon (PA)

Filtering net and cover in stainless steel (AISI 304)
Threaded connection in Nylon (PA)

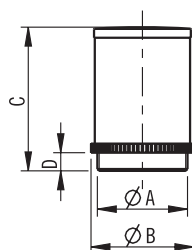

Filtri a rete per soffianti Net-filters for blowers					
Tipo filtro Filter type	Ø A ("gas)	Ø B [mm]	C [mm]	D [mm]	Peso Weight [g]
FR4	1"	40	58	10	18
FR5	1" 1/4	48	68	10	25
FR6	1" 1/2	58	79	10	36
FR7	2"	68	95	12	55
FR8	2" 1/2	83	99	15	78
FR10	3"	100	114	15	126
FR15	4"	127	130	13	172

Filtri a doppio stadio per soffianti Two-stage filters for blowers													
Tipo filtro Filter type	Tipo macchina Machine type	Ø A	Ø B	C	D	Ø E	Ø F	G	X	Ø K	J	Peso Weight [kg]	Tipo cartuccia Cartridge type
		[mm]											
FDS 7/6	CL 12/21 - 14/21	165	60	418	42	143	178	370	95	9	100	4	CH6
FDS 8	CL 17/21 - 20/21 - 23/21 - 28/1 - 34/1	203	70	518	62	270	215	500	108	9	120	6	CH8
FDS 10	CL 30/21 - 36/21 - 40/1	260	89	624	73	270	275	520	127	11,5	146	11	CH10
FDS 14/10	CL 42/21 - 46/1 - 60/1	300	114	520	73	270	320	545	152	13	175	12	CH12
FDS 15/14	CL 49/21 - 72/1 - 84/1	300	127	620	97	307	316	570	152	13	175	14	CH15
FDS 17/14	CL 98/1	355	152	697	108	307	373	645	203	13	206	20	CH17

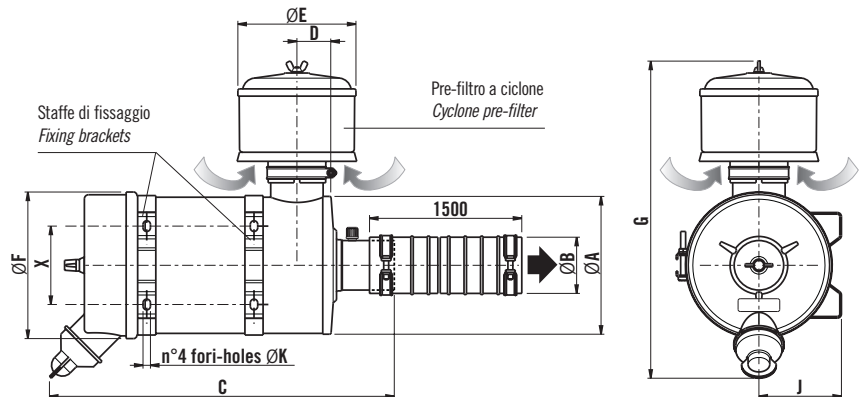

I filtri a doppio stadio, tipo FDS, risultano indicati per l'aspirazione in ambienti con forte presenza di polveri. La maggior parte della polvere contenuta nell'aria aspirata viene separata in un pre-filtro a ciclone e all'interno del corpo metallico del filtro. Una cartuccia in carta trattata, interna al corpo del filtro, provvede poi a trattenere le restanti particelle più fini.

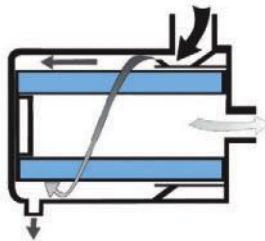

The two-stage filters, FDS type, are suitable for heavy duty applications in environments with strong presence of dust. Most of the dust contained in the sucked air is separated in a cyclone pre-filter and inside the metal housing of the filter. A resin treated paper cartridge, fitted in the filter housing, shall then retain the remaining finest particles of dust.



Indicatori di intasamento ottici ed elettrici

Gli indicatori di intasamento segnalano il momento in cui si deve effettuare la manutenzione dei filtri aria per soffianti. La loro classe di protezione è IP44.

Filter service visual and electrical indicators

The filter service indicators signal when maintenance on air filters fitted on blowers must be carried out. Their protection class is IP44.

Indicatori ottici - Visual indicators



Con l'indicatore ottico la necessità della manutenzione è segnalata dall'apparire di un pistoncino di colore rosso dietro la finestrella trasparente dell'indicatore. Il pistoncino rosso rimane bloccato in posizione di allarme finchè non si effettua manualmente il ripristino premendo sulla testa dell'indicatore.

In the visual indicator the filter restriction limit is shown by a bright red flag that pops up behind the full-view window of the indicator. The red flag stays in the alarm position until the manual reset that is done by pushing on the top of the indicator.

Indicatori elettrici - Electrical indicators



L'indicatore di intasamento elettrico segnala la necessità della manutenzione attraverso la commutazione di un contatto interno che può essere usato per comandare un segnalatore visivo o acustico. La tensione d'alimentazione può essere a 12 o 24V e il carico massimo ammissibile è di 6 Watt. Il resettaggio è automatico dopo la sostituzione o pulizia della cartuccia filtrante.

In the electrical indicator, when the filter restriction level reaches the maximum admissible limit, an internal contact commutes and can be used to activate a light or a buzzer. The feeding voltage can be 12 or 24V and the maximum admissible load is 6 Watt. The indicator automatically resets itself after the cleaning or replacement of the filter cartridge.

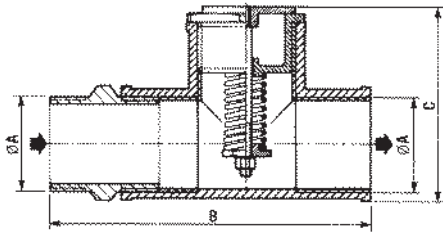

SV4T - SV5/6T - SV6T - SV7T
SV8T - SV8/7T - SV8/10T - SV15T

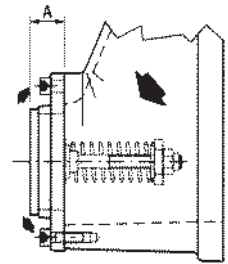

SV7 - SV8 - SV10
SV10D - SV15

Valvole di sovrappressione per soffianti Pressure relief valves for blowers

Tipo valvola Valve type	Tipo macchina Machine type	Ø A ("gas)	B [mm]	C	Peso Weight [kg]
SV4T	CL 3.6/01	1"	310	83	0,9
	CL 4/01				
	CL 4/21		115	0,7	
SV5/4T	CL 30-Z HS	1" 1/4	120	92	0,8
SV5/6T	CL 7/01	1" 1/4	160	95	1,5
	CL 1R3.5				
	CL 7/21				
	CL 220 HS				
SV6T	CL 10/01	1" 1/2	145	95	1,3
	CL 10/21				
	CL 40 HS				
	CL 420 HS				
SV7T	CL 15/01	2"	165	110	2,1
	CL 50 HS				
	CL 1R5.5				
	CL 60 HS				
	CL 520 HS				
	CL 720 HS				
SV8T	CL 18/01 (1,5-2,2kW)	2" 1/2	190	132	3,7
	CL 22/01				
	CL 80-Z HS				
SV8/7T	CL 18/01 (3kW)	2" 1/2	190	150	4
SV8/10T	CL 2R8	2" 1/2	245	148	6,5
SV15T	CL 1R9	4"	260	190	10
	TBT/M				
	CL 2R9				



Valvole di sovrappressione per soffianti Pressure relief valves for blowers

Tipo valvola Valve type	Tipo macchina Machine type	A [mm]	Peso Weight [kg]
SV7	CL 12/21	27	0,6
	CL 14/21		
SV8	CL 28/1	27	0,9
	CL 34/1		
	CL 17/21		
SV10D	CL 23/21	28	1
	CL 40/1		
SV10	CL 20/21	48	1,3
	CL 46/1		
SV10	CL 60/1	27	1
	CL 30/21		
	CL 36/21		
	CL 42/21		
SV15	CL 49/21	32	1,7
	CL 72/1		
	CL 84/1		
SV15	CL 72/1	39	2
	CL 84/1		
SV15	CL 84/1	39	2
	CL 98/1		

Valvole rompivuto per aspiratori Vacuum relief valves for exhausters

Tipo valvola Valve type	Tipo macchina Machine type	Ø A ("gas)	B [mm]	C	Peso Weight [kg]
VSV4	CL 3.6/01	1"	310	105	0,85
	CL 4/01				
	CL 4/21		115	0,65	
VSV5/6	CL 30-Z HS	1" 1/4	160	135	1,5
	CL 7/01				
	CL 1R3.5				
	CL 7/21				
VSV6	CL 220 HS	1" 1/2	145	135	1,3
	CL 10/01				
	CL 40 HS				
	CL 10/21				
	CL 12/21				
	CL 420 HS				
VSV7	CL 15/01	2"	165	155	2
	CL 50 HS				
	CL 1R5.5				
	CL 60 HS				
	CL 14/21				
	CL 520 HS				
	CL 720 HS				
VSV8	CL 18/01	2" 1/2	190	195	3,7
	CL 22/01				
	CL 17/21				
	CL 20/21				
	CL 23/21				
	CL 28/1				
	CL 34/1				
	CL 80-Z HS				
VSV8/10	CL 2R8	2" 1/2	245	228	6,5
	CL 30/21				
VSV10	CL 36/21	3"	220	228	5,6
	CL 42/21				
	CL 40/1				
	CL 46/1				
	CL 60/1				
	CL 49/21				
VSV15	CL 72/1	4"	260	281	10
	CL 84/1				
	CL 98/1				
	TBT/M				
	CL 1R9				
	CL 2R9				
	CL 2R9				

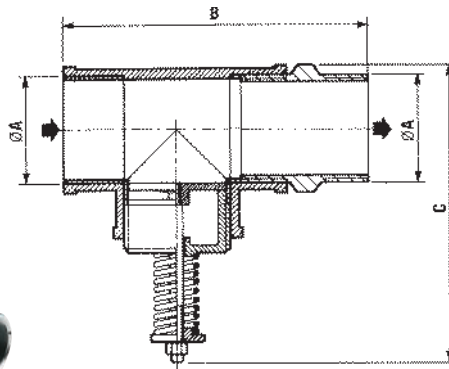

In funzione dell'ambiente di lavoro dell'aspiratore, la valvola rompivuto può essere fornita di silenziatore e/o di filtro di protezione contro l'entrata in macchina di polveri.

Depending on where the exhauster is installed, the vacuum relief valve can be fitted with a silencer, as well as a filter, to prevent ingress of dust into the machine.

Valvole di ritegno Non return valves						
Tipo valvola Valve type	Tipo macchina Machine type	Ø A	B	C	D	Peso Weight [kg]
		("gas)	[mm]			
VR4	CL 20 HS	1"	65	65	42	0,65
	CL 3.6/01					
	CL 4/01					
VR5	CL 4/21	1" 1/4	75	78	48	0,85
	CL 30-Z HS					
	CL 7/01					
	CL 1R3.5					
VR6	CL 7/21	1" 1/2	83	83	52	1
	CL 220 HS					
	CL 10/01					
	CL 40 HS					
VR7	CL 10/21	2"	98	97	59	1,6
	CL 12/21					
	CL 420 HS					
	CL 15/01					
	CL 50 HS					
	CL 1R5.5					
VR8	CL 60 HS	2" 1/2	117	114	67	2,5
	CL 14/21					
	CL 520 HS					
	CL 720 HS					
	CL 18/01					
	CL 22/01					
	CL 17/21					
	CL 20/21					
VR10	CL 23/21	3"	135	133	78	3,5
	CL 28/1					
	CL 34/1					
	CL 80-Z HS					
	CL 2R8					
VR15	CL 30/21	4"	164	162	93	7
	CL 36/21					
	CL 42/21					
	CL 40/1					
	CL 46/1					
	CL 60/1					
	CL 49/21					
	CL 72/1					
CL 84/1						
CL 98/1						
CL 1R9						
CL 2R9						
TBT/M						

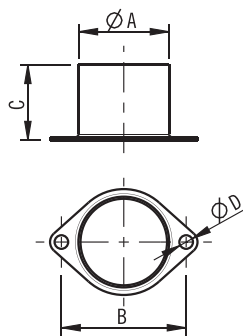
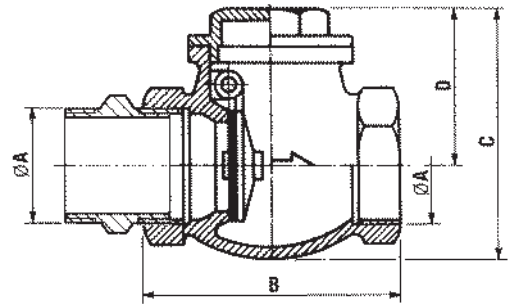

Connessioni flangiate per tubo flessibile Flanged connections for flexible pipe						
Tipo connessione Connection type	Tipo macchina Machine type	Ø A	B	C	Ø D	Peso Weight [kg]
		("gas)	[mm]			
HF 1	CL 30-Z HS	1" 1/4	55-64	50	6,5	0,17
	CL 1R3.5					
	CL 220 HS					
HF 2	CL 40 HS	1" 1/2	72	50	6,5	0,2
	CL 420 HS					
HF 3	CL 50 HS	2"	82,5	50	9	0,24
	CL 1R5.5					
	CL 60 HS					
	CL 520 HS					
CL 720 HS						

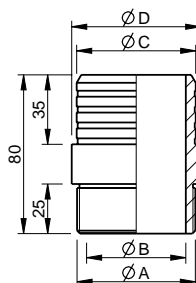
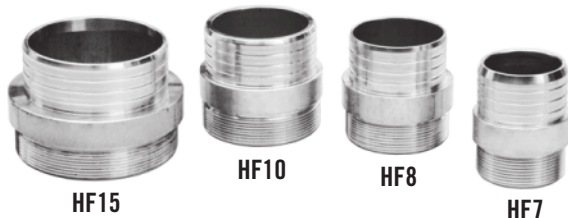

Connessioni filettate per tubo flessibile Threaded connections for flexible pipe					
Tipo connessione Connection type	Ø A	Ø B	Ø C	Ø D	Peso Weight [kg]
	("gas)	[mm]			
HF 7	2"	50	60	65	0,1
HF 8	2" 1/2	64	69	80	0,2
HF 10	3"	70	80	90	0,4
HF 15	4"	90	100	120	0,6

Manicotti flessibili di collegamento <i>Flexible hoses</i>			
Tipo manicotto <i>Valve type</i>	Ø A	B	Peso <i>Weight</i>
	<i>("gas)</i>	<i>[mm]</i>	<i>[kg]</i>
FH4	1"	415	0,5
FH5	1" 1/4	415	0,9
FH6	1" 1/2	420	1,3
FH7	2"	420	0,6
FH8	2" 1/2	420	0,7
FH10	3"	420	1
FH15	4"	420	1,5

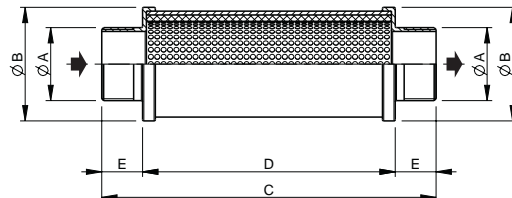
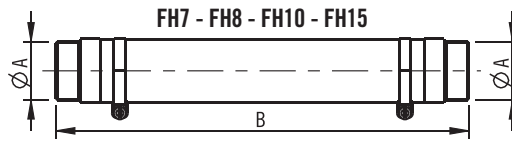
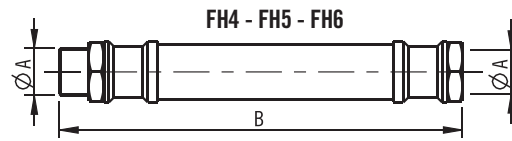

Silenziatori a doppia connessione <i>Two-connection silencers</i>						
Tipo silenziatore <i>Silencer type</i>	Ø A	Ø B	C	D	E	Peso <i>Weight</i>
	<i>("gas)</i>	<i>[mm]</i>				<i>[kg]</i>
SSI 4	1"	69	178	138	20	0,4
SSI 5	1" 1/4	69	242	138	52	0,5
SSI 6	1" 1/2	80	232	168	32	0,5
SSI 7	2"	89	262	198	32	0,6
SSI 8	2" 1/2	100	262	198	32	1,1
SSI 10	3"	152	430	350	40	1,3
SSI 15	4"	152	480	400	40	2,5

Silenziatori a singola connessione <i>Single connection silencers</i>							
Tipo silenziatore <i>Silencer type</i>	Ø A	Ø B	C	D	E	Ø F	Peso <i>Weight</i>
	<i>("gas)</i>	<i>[mm]</i>					<i>[kg]</i>
SSF 4	1"	69	158	138	20	34	0,3
SSF 5	1" 1/4	69	190	138	52	42	0,4
SSF 6	1" 1/2	80	200	168	32	48	0,4
SSF 7	2"	89	230	198	32	60	0,5
SSF 8	2" 1/2	100	230	198	32	75	0,9
SSF 10	3"	152	390	350	40	89	1,1
SSF 15	4"	152	440	400	40	114	1,9

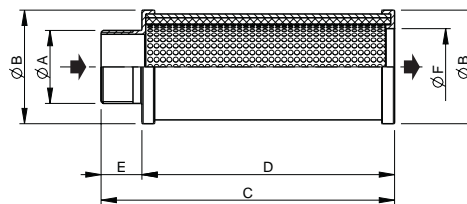

Manometri e vuotometri a bagno di glicerina
Glycerine filled pressure and vacuum gauges

Cassa inox
Attacco radiale da 1/4" gas
Scale standard: manometri: 0÷0,5 bar
0÷1 bar
vuotometri: 0÷ -100 kPa

Stainless steel case
Bottom connection G 1/4"
Normalized range: pressure gauges: 0÷0,5 bar
0÷1 bar
vacuum gauges: 0÷ -100 kPa

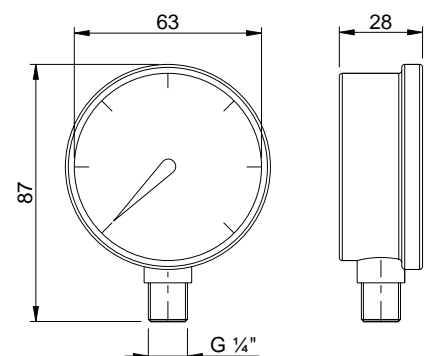

Cabine insonorizzanti

Per ogni tipo di macchina sono disponibili cabine insonorizzanti costituite da pannelli, con lamiera esterna zincata, smontabili singolarmente. I pannelli sono uniti tra loro con ganci esterni di bloccaggio anch'essi zincati o, su richiesta, in acciaio inox.

L'abbattimento acustico è mediamente di 12 dB(A).

Le cabine per tutti gli aspiratori a canale laterale e per le soffianti con motore di potenza superiore a 4 kW sono dotate di elettroventilatore, con convogliamento insonorizzato, per il necessario ricircolo d'aria.

Per le dimensioni delle cabine e per informazioni più dettagliate, vi preghiamo di contattare il nostro Servizio Vendite.



Acoustic enclosures

Acoustic enclosures are available for each type of machine. They are made up from independently removable acoustic panels externally clad with galvanized sheet steel. The panels are fixed together with externally mounted clamps, galvanized as well. On request, clamps in stainless steel could be supplied. Sound pressure levels are reduced by about 12 dB(A).

The acoustic enclosures, for all side channel exhausters and for blowers with motor power above 4 kW, are fitted with an electrically operated ventilation fan with sound deadened duct.

Please contact our Sales Department for detailed information and for the dimensions of the acoustic enclosures.

Dispositivi di inversione di flusso

I dispositivi di inversione di flusso, costruiti in lega di alluminio, vengono impiegati per invertire la direzione di moto dell'aria in un condotto in tempi dell'ordine di qualche decimo di secondo.

Possono essere azionati da comando pneumatico a pistone o da elettromagnete alimentato a 230V in c.a. monofase o a 24V in c.c.

Oltre ai tipi qui sotto illustrati, a singolo pistone, sono disponibili altri dispositivi di inversione di flusso con due pistoni indipendenti e doppio azionamento pneumatico. Per informazioni più dettagliate, prego contattare il nostro Servizio Vendite.

Flow changeover devices

The flow changeover devices, made of aluminium alloy, can be used to reverse the air flow direction in a pipeline in a time round to some tenth of a second.

They can be operated by pneumatic actuator or electromagnet with 230V a.c. or 24V d.c. feeding.

Besides the versions with single piston shown below, other devices are also available with two independent pistons and two pneumatic actuators. Please contact our Sales Department for more detailed information.

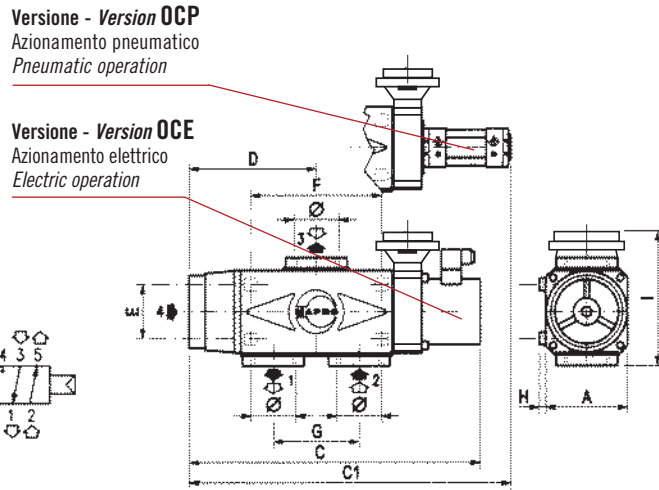
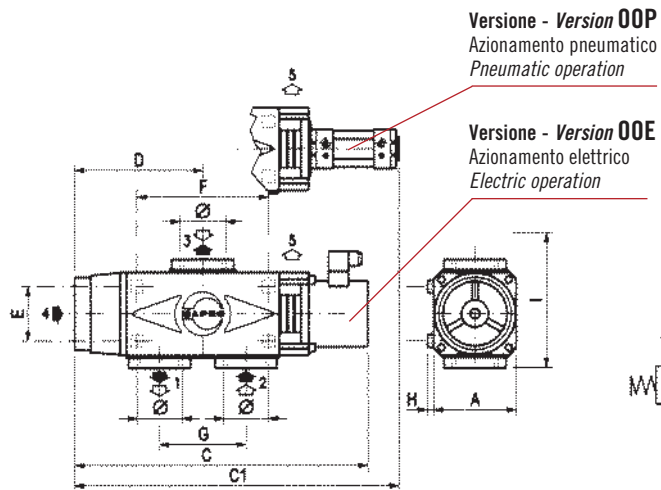

Tipo dispositivo Device type	A	B	C	C1	D	E	F	G	H	I	Attacchi Connect. Ø	Peso con comando pneumatico Weight with pneumatic feeding	Peso con comando elettrico Weight with electric feeding
	[mm]										("gas)	[kg]	
FCD7	100	143	403	417	165	66	168	105	7	175	2"	4,3	6,8
FCD10	150	206	502	516	219	88	256	155	7	266	3"	9	11,5



SOFFIANTI A CANALE LATERALE PER GAS COMBUSTIBILI SIDE CHANNEL BLOWERS FOR COMBUSTIBLE GASES

Soffianti per biogas, gas naturale o gas combustibili, per Zone 1 e 2, secondo la Direttiva 94/9/CE (ATEX)



Generalità costruttive

Per l'aspirazione o la compressione di gas combustibili quali gas biologico o gas metano, è stata messa a punto, per tutta la gamma di soffianti a canale laterale, una linea di macchine a tenuta ermetica, caratterizzata da una specifica tecnologia costruttiva MAPRO®, identificata dal marchio:

MAPROBioGas
Technology

Le principali peculiarità costruttive di tali macchine sono:

- carcasse e giranti interamente in lega di alluminio antiscintilla;
- trattamento di impregnazione con Loctite delle parti destinate a contenere il gas;
- sigillatura tra i fondi e le eventuali sezioni intermedie costituenti i corpi macchina;
- tenuta sull'albero realizzata con speciali anelli a doppio labbro che non richiedono lubrificazione;
- motori elettrici in esecuzione antideflagrante, con modo di protezione minimo Ex-d II BT3 - IP 55 per Zona 1; motori elettrici in esecuzione antiscintilla, con modo di protezione minimo Ex-nA II T3 - IP 65 per Zona 2.

A richiesta possono essere forniti motori conformi alle norme NEMA, SABS, ecc. La soluzione costruttiva più semplice prevede la cosiddetta esecuzione "MONOBLOCCO". La flangia anteriore del motore elettrico è cioè direttamente fissata al corpo macchina e la girante, bilanciata dinamicamente, è calettata sul capo d'albero del motore stesso. Possono inoltre essere fornite macchine con proprio albero e cuscinetti, accoppiate al motore elettrico tramite giunto elastico o a mezzo cinghie e pulegge. I carter di protezione delle trasmissioni saranno in tal caso in materiale antiscintilla.



Applicazioni più comuni

- Aspirazione di biogas da discariche controllate e invio a torcia, a bruciatore o motore a gas;
- aspirazione di gas da serbatoi, impianti o terreni da bonificare e invio a torcia o a bruciatore;
- aspirazione di biogas da gasometro, di gas naturale da rete o da gasometro e invio a bruciatore o motore a gas.

Blowers for biogas, natural gas or combus- tible gases, for Zones 1 and 2, in conformity with the 94/9/EC Directive (ATEX)



Features of construction

To extract or compress combustible gases, such as biological gas or methane gas, a complete range of gas-tight side channel blowers has been designed, featuring a specific MAPRO® manufacturing technology, identified by the trademark:

MAPROBioGas
Technology

The main characteristics of construction of these machines are:

- casing and impellers made completely of spark proof aluminium alloy;
- static parts in contact with the gas impregnated with Loctite;
- casing halves sealed;
- shaft sealing by special double-lip seals which do not require lubrication;
- explosion-proof electric motors, with minimum protection class Ex-d IIB T3 - IP 55 for Zone 1; non-sparking motors, with maximum protection class Ex-nA II T3 - IP 65 for Zone 2.

Motors in accordance with NEMA, SABS and other Standards can be supplied upon request. The simplest solution for the manufacturing of the machines is the so-called "CLOSE COUPLED" version - i.e., a flange mounted electric motor is bolted to the blower casing; the impeller, which is dynamically balanced, is fitted directly onto the motor shaft extension.

Furthermore we can offer machines with their own shaft and bearings and coupled to the electric motors via flexible shaft couplings or belt drives. In these cases, the safety drive guards are made from spark-free material.

The most common fields of applications

- Landfill biogas recovery to feed torch, burner or gas engine;
- tank, plant or contaminated soil gas recovery to feed torch or burner;
- extraction of biogas from gasometer, natural gas from pipeline or gasometer and burner or gas engine feeding.



Macchine con ricircolo del gas (by-pass)

Per tutti i casi in cui il gas aspirato debba essere inviato ad un bruciatore o comunque ad un utilizzo che richieda una portata variabile nel tempo, un sistema semplice ed efficace per soddisfare tale variabilità è costituito da un by-pass tra la mandata e l'aspirazione sul quale viene installata un'opportuna valvola di sovrappressione. Allorché la portata richiesta all'utilizzo diminuisce, la pressione alla mandata tende ad aumentare. Al raggiungimento della pressione di taratura, la valvola di sovrappressione inizia ad aprirsi ed a ricircolare la portata di gas in esubero. Il by-pass consente abitualmente il ricircolo dell'intera portata e la macchina può quindi continuare a funzionare anche se l'utilizzo non richiede gas. Nel caso in cui il ricircolo completo non sia possibile senza raffreddamento del gas, sarà previsto un adeguato raffreddatore a fascio tubiero.



Macchine azionate tramite inverter

Nel caso in cui la portata di gas richiesta all'utilizzo sia variabile nel tempo (bruciatore o motore a gas), possono essere fornite soffianti con motore destinato ad essere alimentato tramite inverter. Il campo di variazione della velocità di rotazione della macchina (e quindi della frequenza di alimentazione del motore elettrico) sarà definito in funzione delle condizioni di lavoro previste, in particolare del differenziale di pressione tra aspirazione e mandata della macchina. La regolazione della velocità di rotazione potrà essere fatta in funzione del controllo del parametro "pressione di mandata".

Accessori

È disponibile una linea completa di accessori che comprende, tra l'altro:

- filtri a tenuta stagna;
- compensatori flangiati di collegamento con soffietto inox;
- valvole di ritegno;
- manometri e termometri;
- pressostati e termostati;
- valvole di esclusione manuali ed automatiche;
- cabine insonorizzanti.



Per maggiori dettagli sulle soffianti a canale laterale per gas combustibili, in particolare per biogas, prega richiedere al nostro Servizio Vendite la brochure specifica COD. 0108.



Machines with gas recirculation (by-pass)

When a variable flow rate is required, a by-pass line between outlet and inlet, and in which a suitable pressure relief valve is fitted, is a simple and effective solution.

When the gas demand decreases, the outlet pressure increases, and, when the set pressure is reached, the pressure relief valve begins to open and by-passes gas back to the blower suction.

Usually, the by-pass circuit is capable of handling the full capacity of the blower and thus the machine can continue to run even if the downstream gas demand is zero.

A suitable cooler will be installed if complete recirculation is not possible without gas cooling.

Machines controlled via frequency inverter

If the gas demand varies in time (such as for burner or engine feeding), we can supply blowers equipped with a motor intended for control via frequency inverter. The rpm range of the blower (and therefore the output frequency range of the frequency inverter) can be adjusted according to the foreseen operating conditions, and in particular to the expected differential pressure between blower discharge and suction. The speed of rotation of the motor shall be controlled via the "discharge gas pressure" process parameter.

Accessories

A complete range of accessories is available, including the following:

- gas-tight filters;
- stainless steel flanged flexible connection bellows;
- non return valves;
- pressure gauges and thermometers;
- pressure switches and temperature switches;
- manual and automatic cut-off valves;
- acoustic enclosures.



For more details on side channel blowers for combustible gases, more specifically for biogas, please ask to our Sales Department the specific brochure COD. 0108.

SOFFIANTI E ASPIRATORI TBT

TBT BLOWERS AND EXHAUSTERS

Le soffianti e gli aspiratori TBT sono macchine con canale toroidale periferico, come le soffianti a canale laterale, ma con una girante e un canale di concezione altamente innovativa, frutto di un lungo lavoro di ricerca e sperimentazione. Le palette a profilo alare della girante e il canale con nocciolo centrale consentono di raggiungere prestazioni paragonabili a quelle delle soffianti volumetriche a lobi rotanti con, in più, alcuni notevoli vantaggi:

- rumorosità notevolmente contenuta (inferiore di 10÷15 dB a quella di una macchina a lobi);
- assenza di vibrazioni;
- assenza di pulsazioni nel gas trattato;
- assenza di inquinamento del gas;
- minima manutenzione, ridotta a pulizia del filtro in aspirazione e lubrificazione periodica, dall'esterno, con grasso, dei cuscinetti.

La sostituzione straordinaria dei cuscinetti può essere effettuata senza smontaggio del corpo macchina.

Nelle soffianti TBT il gas passa lungo due canali che lavorano in parallelo. È anche possibile escludere l'ingresso e l'uscita su uno dei due canali, ottenendo così una macchina (TBT-HF) con portata dimezzata a pari pressione di mandata. L'ampia gamma di velocità di rotazione ammissibili (da 2000 giri/min a 5500 giri/min) consente di coprire, con una sola taglia di macchina, un larghissimo campo di funzionamento.

Carcassa e girante in lega d'alluminio ed albero in acciaio legato consentono, con alcune modifiche per la tenuta, di trattare la maggior parte dei gas tecnici, tra i quali gas naturale e gas biologico.

Nel caso di gas corrosivi, tutte le parti in contatto con i gas stessi possono essere trattate superficialmente o dotate di rivestimenti protettivi.

È disponibile, per soddisfare ogni applicazione, una linea completa di accessori, tra cui: filtri, silenziatori, manicotti flessibili di collegamento, valvole di ritegno, valvole di sovrappressione e rompivuoto, valvole manuali od automatiche di esclusione, manometri, termometri, vuotometri, pressostati, cabine insonorizzanti.

The TBT blowers and exhausters are machines with a peripheral toroidal channel, similar to side channel blowers, but with a revolutionary heliflow impeller and channel developed through long research and tests. With this impeller and channel design, performances similar to positive displacement machines can be achieved, with none of the associated problems and, indeed, with some added advantages:

- *quiet operation (10÷15 dB less than a positive displacement machine);*
- *vibration free;*
- *pulsation free;*
- *oil free;*
- *low maintenance (inlet filter cleaning and occasional greasing of the bearings only).*

Bearing replacement can be carried out without disassembling the machine casing.

In the TBT design, the aspirated gas is forced along the two peripheral channels in parallel, or, by modifying the inlet and outlet porting, one of the channels can be excluded thus obtaining a machine (TBT-HF) with half the flow rate at the same outlet pressure.

Because of the wide range of permissible operating speeds of rotation (from 2000 to 5500 rpm), a very large operating range

can be achieved using a single machine size.

The casing and impeller are made from aluminium alloy and the shaft from alloy steel.

By using different types of shaft sealing, most industrial gases as well as natural and biological gases can be handled. In the case of corrosive gases, the internal wetted parts can be treated or lined with protective coatings.

To suit all applications, a complete range of accessories is available, such as: filters, silencers, flexible hoses, non return valves, pressure and vacuum relief valves, manual and automatic cut-off valves, pressure gauges, thermometers, vacuum gauges, temperature switches, pressure switches, acoustic enclosures.

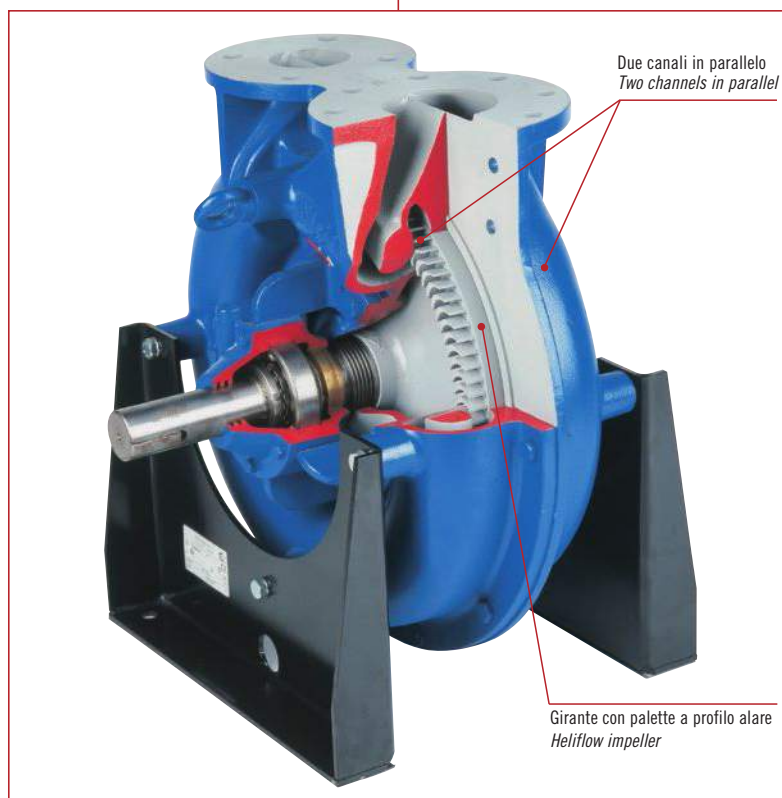

Soffiante TBT - dimensioni TBT blower - dimensions



Nota / Note:
Disponibile anche in esecuzione per Zone 1 e 2, 21 e 22 della Direttiva Europea 94/9/CE (ATEX).
Also manufactured in conformity to the requirements of the European Directive 94/9/EC (ATEX) for Zones 1 and 2, 21 and 22.

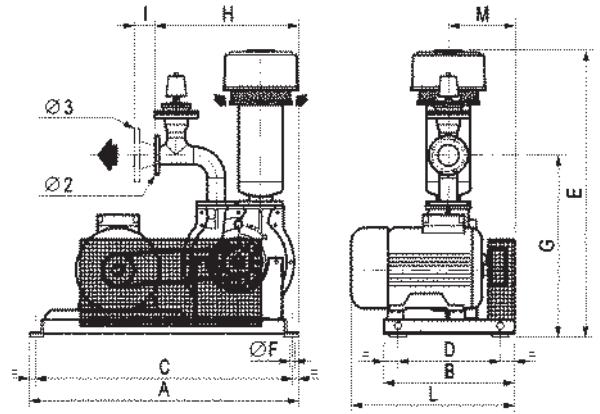

Potenza motore Motor power [kW]	Poli motore Motor poles	Dimensioni [mm] Dimensions [mm]											Attacchi flangiati Flanged connections		Peso Weight [kg]																			
		A	B	C	D	E	ØF	G	H	I	L	M	mandata outlet outlet Ø 2	mandata outlet outlet Ø 3																				
11	2 o/ or 4	1340	650	1280	510	1430	20	900	550	135	670	330	Per portate ≤ 600 m³/h	Per portate > 600 m³/h	385																			
15	2															670	395																	
	4															695	405																	
18,5	2 o/ or 4															1340	650	1280	510	1430	20	900	550	135	700	330	Per portate ≤ 600 m³/h	Per portate > 600 m³/h	415					
22	2																													705	435			
	4																													740	450			
30	2 o/ or 4																													1350	800	1150	750	1480
	37	2	820	520																														
4		860	535																															
45	2	1350	800	1150	750	1480	20	950	630	135	860	330	PN10 DN80	PN10 DN125	560																			
	55															4	885	565																
2 o/ or 4																1000	950	950	1150	885	565													
75	2 o/ or 4																					950	750											

Aspiratore TBT - dimensioni TBT exhauster - dimensions



Nota / Note:
Disponibile anche in esecuzione per Zone 1 e 2, 21 e 22 della Direttiva Europea 94/9/CE (ATEX).
Also manufactured in conformity to the requirements of the European Directive 94/9/EC (ATEX) for Zones 1 and 2, 21 and 22.

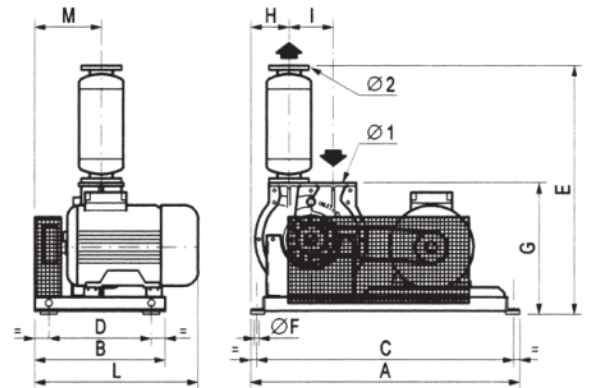

Potenza motore Motor power [kW]	Poli motore Motor poles	Dimensioni [mm] Dimensions [mm]											Attacchi flangiati Flanged connections		Peso Weight [kg]																
		A	B	C	D	E	ØF	G	H	I	L	M	aspirazione inlet inlet Ø 1	mandata outlet outlet Ø 2																	
11	2 o/ or 4	1340	650	1280	510	1240	20	650	190	220	670	330	PN10 DN100	PN10 DN80	355																
15	2															670	360														
	4															695	365														
18,5	2 o/ or 4															1340	650	1280	510	1240	20	650	190	220	700	330	PN10 DN100	PN10 DN80	380		
22	2																													705	400
	4																													740	415
30	2 o/ or 4																													1350	800
	37	2	820	485																											
4		860	500																												
45	2	1350	800	1150	750	1290	20	700	110	220	860	330	PN10 DN100	PN10 DN80	525																
	55															4	860	530													
75																2 o/ or 4	530	530													

Soffiante TBT

I valori riportati sono riferiti ad aria alle condizioni di aspirazione di 20°C e 101,3 kPa ass. = 1013 mbar ass.

TBT blower

The diagrams values refer to air at the suction conditions of 20°C and 101,3 kPa abs. = 1013 mbar abs.

TBT
(due canali operanti)
(two operating channels)

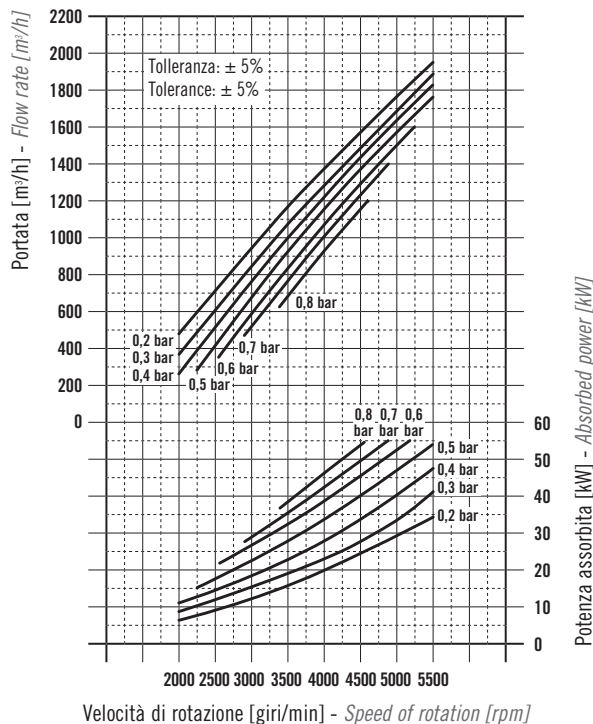

TBT-HF
(un solo canale operante)
(only one operating channel)

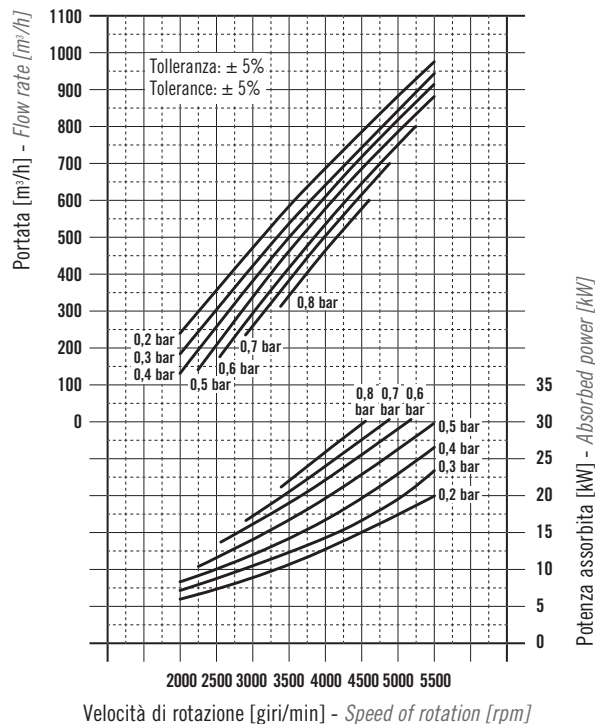

Nota / Note:

Disponibile anche in esecuzione per Zone 1 e 2, 21 e 22 della Direttiva Europea 94/9/CE (ATEX).

Also manufactured in conformity to the requirements of the European Directive 94/9/EC (ATEX) for Zones 1 and 2, 21 and 22.

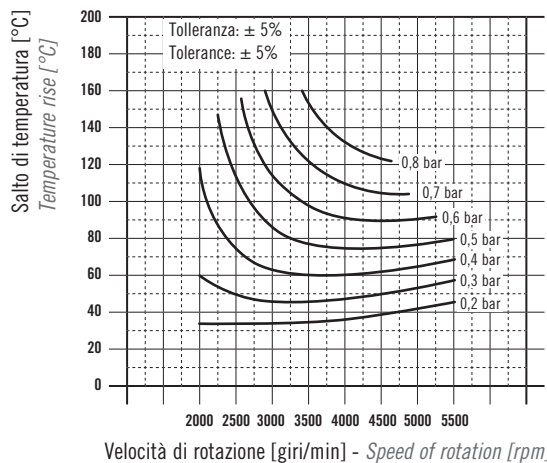

Rumorosità dB(A) ad 1 m
Sound level dB(A) at 1 m

Velocità di rotazione [giri/min] Speed of rotation [rpm]	Pressione di mandata [bar]							
	0,1	0,2	0,3	0,4	0,5	0,6	0,7	0,8
2000	75	75	75	76				
2500	76	76	76	77	78			
3000	79	79	80	81	82	83	84	
3500	80	80	81	82	82	84	85	86
4000	81	82	83	84	84	85	87	88
4500	82	83	84	85	86	87	88	89
5000	83	84	85	86	87	88	89	
5500	85	86	87	88	89			

Tolleranza: ± 3 dB(A)

I valori di rumorosità sono per soffianti con motore a 2 poli. Con motore a 4 poli la rumorosità può risultare ancora inferiore.

Tolerance: ± 3 dB(A)

The sound levels are for blowers with 2 pole motor. With 4 pole motor the sound level can even be lower.

Soffiante TBT con due canali operanti - Tabella prestazioni TBT blower with two operating channels - Performance table

Pressione di mandata Outlet pressure [hPa=mbar]	[giri/min] [rpm]	2000	2250	2500	2750	3000	3250	3500	3750	4000	4250	4500	4750	5000	5250	5500
		200	Q [m³/h]	470	585	700	815	925	1035	1145	1250	1355	1455	1555	1655	1755
	Δt [°C]	33	32	32	32	33	34	34	35	36	37	38	39	41	43	47
	N [kW]	5,9	7,1	8,5	9,9	11,6	13,2	14,8	16,8	18,8	21	23,2	25,5	27,8	30,2	34,5
250	Q [m³/h]	415	535	650	765	880	995	1105	1210	1315	1420	1520	1620	1720	1820	1910
	Δt [°C]	44	41	40	39	39	39	39	41	42	43	44	45	46	48	52
	N [kW]	7	8,4	9,9	11,5	13,2	14,9	16,7	18,8	20,9	23,1	25,3	27,7	30,5	33,3	37,5
300	Q [m³/h]	355	480	600	720	835	950	1060	1170	1275	1380	1485	1585	1685	1785	1875
	Δt [°C]	60	52	49	47	46	46	46	47	48	49	50	51	53	55	57
	N [kW]	8,2	9,7	11,3	13	14,8	16,7	18,7	20,8	23	25,2	27,5	30	33,2	36,4	40,9
350	Q [m³/h]	295	430	550	670	790	910	1020	1130	1235	1340	1445	1545	1645	1745	1840
	Δt [°C]	83	67	61	57	54	53	53	53	54	55	56	57	59	61	63
	N [kW]	9,3	11	12,7	14,5	16,4	18,4	20,5	22,8	25,3	28	30,8	33,7	37	40,4	44,3
400	Q [m³/h]	235	368	500	625	745	860	975	1085	1195	1305	1410	1515	1620	1715	1810
	Δt [°C]	118	88	75	69	63	62	61	61	61	62	63	64	66	69	
	N [kW]	10,7	12,4	14,2	16,1	18,1	20,2	22,5	25	27,7	30,5	33,3	36,3	39,7	43,2	47,2
450	Q [m³/h]		310	450	575	700	820	935	1050	1165	1270	1375	1480	1585	1685	1780
	Δt [°C]		117	92	81	74	70	69	68	67	68	68	69	71	72	74
	N [kW]		14	15,9	17,8	19,7	22	24,6	27,2	29,9	32,9	36	39,2	42,8	46,5	50,4
500	Q [m³/h]		265	400	530	655	780	900	1015	1130	1240	1345	1450	1555	1655	1750
	Δt [°C]		147	114	96	86	80	77	75	74	74	75	76	77	78	80
	N [kW]		15,6	17,5	19,5	21,5	23,8	26,3	29,1	32,1	35,3	38,7	42,2	45,8	49,5	53,6
550	Q [m³/h]			352	490	615	735	855	975	1090	1200	1310	1420	1525	1625	
	Δt [°C]			141	113	99	92	88	84	83	82	82	83	84	85	
	N [kW]			19	20,9	23,1	25,8	28,6	31,5	34,6	37,8	41,1	44,7	48,5	52,4	
600	Q [m³/h]				445	575	695	815	935	1055	1165	1275	1385	1495	1595	
	Δt [°C]				132	113	105	99	94	91	90	90	90	91	91	
	N [kW]				22,4	24,9	27,7	30,6	33,6	36,6	40	43,6	47,3	51,2	55,4	
650	Q [m³/h]				407	535	655	775	895	1015	1130	1245	1355	1465		
	Δt [°C]				152	131	119	111	105	101	99	98	97	97		
	N [kW]				23,6	26,6	29,7	32,8	35,9	39,1	42,6	46,3	50,3	54,6		
700	Q [m³/h]					495	620	740	860	980	1095	1210	1325			
	Δt [°C]					150	132	122	115	110	108	106	105			
	N [kW]					28,4	31,4	34,6	37,9	41,3	45	48,9	52,9			
750	Q [m³/h]						575	700	825	945	1060	1175	1290			
	Δt [°C]						153	137	127	121	118	115	112			
	N [kW]						33,5	36,7	40	43,6	47,4	51,4	55,5			
800	Q [m³/h]							665	788	908	1025	1148				
	Δt [°C]							152	140	133	128	124				
	N [kW]							38,6	42	46	50	53,8				

I valori di tabella sono riferiti ad aria alle condizioni di aspirazione di 20°C e 101,3 kPa ass. = 1013 mbar ass.

Q : portata aspirata - Tolleranza: ± 5%

Δt: incremento di temperatura - Tolleranza: ± 5%

N : potenza assorbita all'albero della soffiante TBT - Tolleranza: ± 5%

The values shown in the table refer to air at the suction conditions of 20°C and 101,3 kPa abs. = 1013 mbar abs.

Q : flow rate - Tolerance: ± 5%

Δt: temperature rise - Tolerance : ± 5%

N : absorbed power at TBT blower shaft - Tolerance: ± 5%



Aspiratore TBT

I valori riportati sono riferiti ad aria a 20°C. I valori di portata si intendono alla pressione di aspirazione. La pressione di mandata è considerata a 101,3 kPa ass. = 1013 mbar ass.

TBT exhauster

The diagram values refer to air at 20°C. The flow rates refer to the suction pressure. The discharge pressure is considered at 101,3 kPa abs. = 1013 mbar abs.

TBT

(due canali operanti)
(two operating channels)

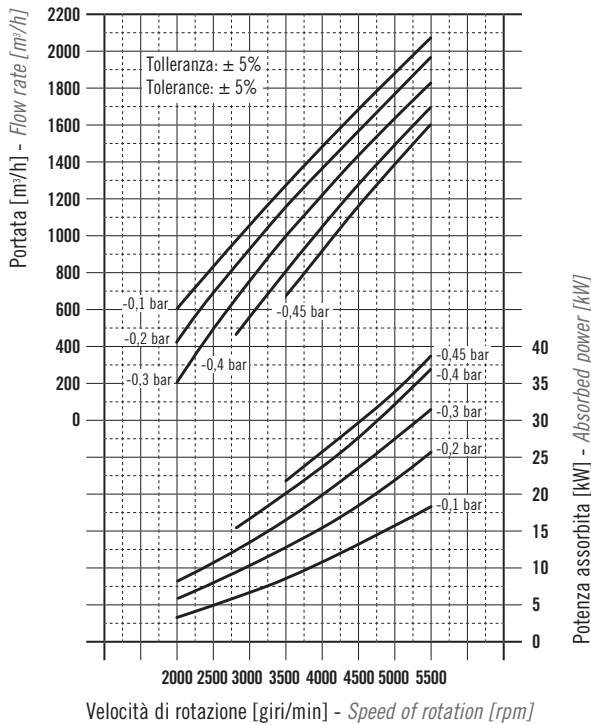

TBT-HF

(un solo canale operante)
(only one operating channel)

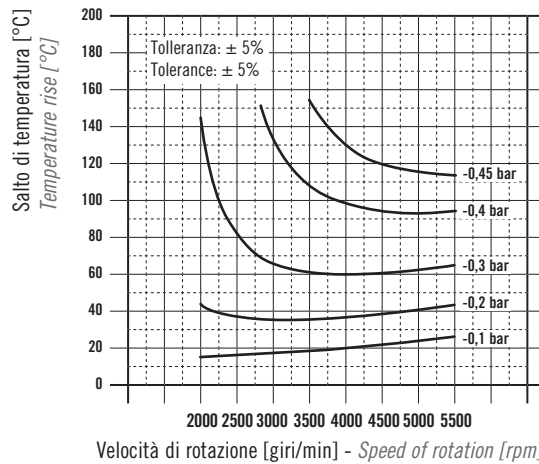
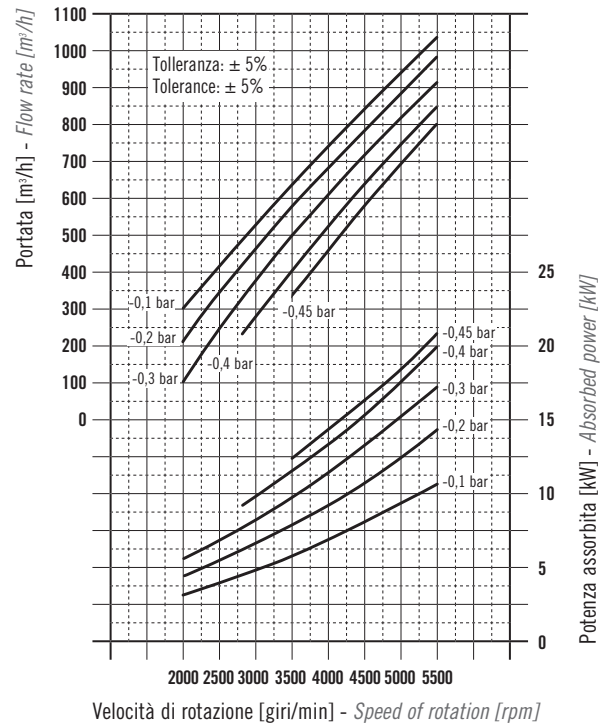

Note / Note:
Disponibile anche in esecuzione per Zone 1 e 2, 21 e 22 della Direttiva Europea 94/9/CE (ATEX).
Also manufactured in conformity to the requirements of the European Directive 94/9/EC (ATEX) for Zones 1 and 2, 21 and 22.

Rumorosità dB(A) ad 1 m Sound level dB(A) at 1 m

Velocità di rotazione [giri/min] Speed of rotation [rpm]	Depressione all'aspirazione [bar] Inlet vacuum [bar]							
	-0,1	-0,15	-0,2	-0,25	-0,3	-0,35	-0,4	-0,45
2000	75	75	75	76	76			
2500	76	76	77	77	77	78		
3000	78	78	78	79	79	79	80	
3500	80	80	80	81	81	81	81	82
4000	81	81	81	82	82	82	82	83
4500	82	82	82	83	83	83	84	84
5000	84	84	84	84	84	85	85	85
5500	84	84	84	85	85	85	86	86

Tolleranza: ± 3 dB(A)

I valori di rumorosità sono per aspiratori con motore a 2 poli. Con motore a 4 poli la rumorosità può risultare ancora inferiore.

Tolerance: ± 3 dB(A)

The sound levels are for exhausters with 2 pole motor. With 4 pole motor the sound level can even be lower.

Aspiratore TBT con due canali operanti - Tabella prestazioni TBT exhauster with two operating channels - Performance table

Depressione all'aspirazione <i>Inlet vacuum</i> [hPa=mbar]	[giri/min]															
	<i>[rpm]</i>	2000	2250	2500	2750	3000	3250	3500	3750	4000	4250	4500	4750	5000	5250	5500
-100	Q [m³/h]	595	710	825	940	1053	1163	1265	1365	1465	1565	1665	1765	1865	1965	2070
	Δt [°C]	16	16	16	17	17,5	18	19	20	21	22	23	24	25	26	27
	N [kW]	3,3	4	4,7	5,5	6,4	7,3	8,4	9,5	10,6	11,7	12,8	14	15,4	17	18,7
-150	Q [m³/h]	505	630	750	865	980	1090	1200	1310	1410	1510	1610	1710	1810	1910	2015
	Δt [°C]	27	26	25	25	26	26,5	27	27,5	28	29	30	31	33	35	37
	N [kW]	4,4	5,2	6,1	7,1	8,2	9,3	10,5	11,7	13	14,3	15,6	16,9	18,6	20,7	23,5
-200	Q [m³/h]	415	540	665	785	905	1020	1130	1240	1350	1450	1550	1650	1760	1860	1965
	Δt [°C]	44	39	37	36	35,5	35	36	36,5	37	37,5	38	39	40	41	43
	N [kW]	5,6	6,5	7,5	8,6	9,8	11,1	12,5	13,9	15,3	16,7	18,1	19,8	21,7	23,7	25,9
-250	Q [m³/h]	310	440	570	700	820	935	1050	1165	1280	1385	1485	1590	1695	1795	1900
	Δt [°C]	76	62	56	50	49	48	47,5	47	47	47,5	48	48,5	50	51,5	53
	N [kW]	6,8	7,9	9	10,1	11,4	12,8	14,3	15,8	17,3	18,9	20,5	22,2	24,2	26,4	28,8
-300	Q [m³/h]	205	340	475	605	735	855	970	1085	1200	1310	1415	1520	1625	1730	1830
	Δt [°C]	146	102	83	72	65	63	62	61	60,5	60	61	61,5	62	63	65
	N [kW]	8,1	9,3	10,5	11,7	12,9	14,4	16	17,7	19,4	21,1	23	24,9	27	29,1	31,6
-350	Q [m³/h]			370	505	630	755	875	995	1115	1230	1340	1450	1560	1660	1760
	Δt [°C]			130	105	93	86	82	79	77	76	75,5	75,5	76	77	78
	N [kW]			12	13,3	14,6	16,2	17,9	19,7	21,5	23,3	25,3	27,3	29,5	31,7	34,1
-400	Q [m³/h]					525	655	780	900	1020	1140	1255	1370	1480	1585	1685
	Δt [°C]					135	118	109	103	99	96	95	94	93,5	93	94
	N [kW]					16,3	17,9	19,7	21,5	23,4	25,4	27,5	29,6	31,9	34,5	36,5
-450	Q [m³/h]							660	785	910	1035	1155	1275	1395	1505	1610
	Δt [°C]							154	140	132	124	120	117	115	113	113
	N [kW]								21,5	23,4	25,4	27,4	29,5	31,6	33,9	36,2

I valori di tabella sono riferiti ad aria a 20°C.

I valori di portata si intendono alla pressione di aspirazione.

La pressione di mandata è considerata a 101,3 kPa ass. = 1013 mbar ass.

Q : portata riferita alle condizioni di aspirazione - Tolleranza : ± 5%

Δt: incremento di temperatura - Tolleranza : ± 5%

N : potenza assorbita all'albero dell'aspiratore TBT - Tolleranza : ± 5%

The values shown in the table refer to air at 20°C.

The flow rates refer to the suction pressure.

The discharge pressure is considered at 101,3 kPa abs. = 1013 mbar abs.

Q : flow rate at the suction conditions - Tolerance : ± 5%

Δt: temperature rise - Tolerance : ± 5%

N : absorbed power at TBT exhauster shaft - Tolerance : ± 5%





Unità produttiva "Vesuvio"

"Vesuvio" factory



Unità produttiva "Fermi"

"Fermi" factory



Magazzino "Cinisello"

"Cinisello" warehouse

Altri prodotti MAPRO®

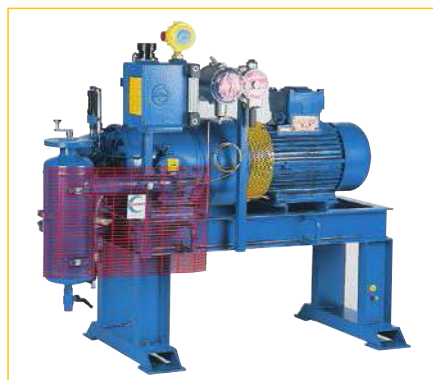

Compressori rotativi a palette per aria e gas
Sliding vane rotary compressors for air and gases



Other MAPRO® products

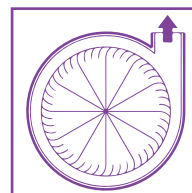

Ventilatori centrifughi per aria e gas
Centrifugal fans for air and gases



Soffianti e aspiratori centrifughi multistadio per aria e gas
Multistage centrifugal blowers and exhausters for air and gases

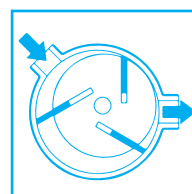
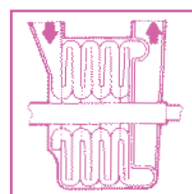

Pompe per vuoto rotative a palette a ricircolo d'olio e a secco
Rotary vane vacuum pumps, oil recirculating type and oil free

Questo catalogo, nella logica del miglioramento continuo, è soggetto a revisione. Per informazioni sulla versione in vigore, contattare il Servizio Vendite.
In the logic of continuous improvement, this catalogue is subject to revision. Please contact our Sales Department for information on the version in force.



MAPRO INTERNATIONAL SpA
Macchine Pneumatiche Rotative
Via Vesuvio, 2
20834 NOVA MILANESE (MB) - Italy
Tel. +39 0362 366356
Fax +39 0362 450342
www.maproint.com • E-mail: mapro@maproint.com