

VX LINE

Raccordi a Funzione in Acciaio Inox 316L
316L Stainless Steel Function Fittings
Raccords à fonction en Acier Inox 316L
Funktionsverschraubungen aus Edelstahl 1.4404

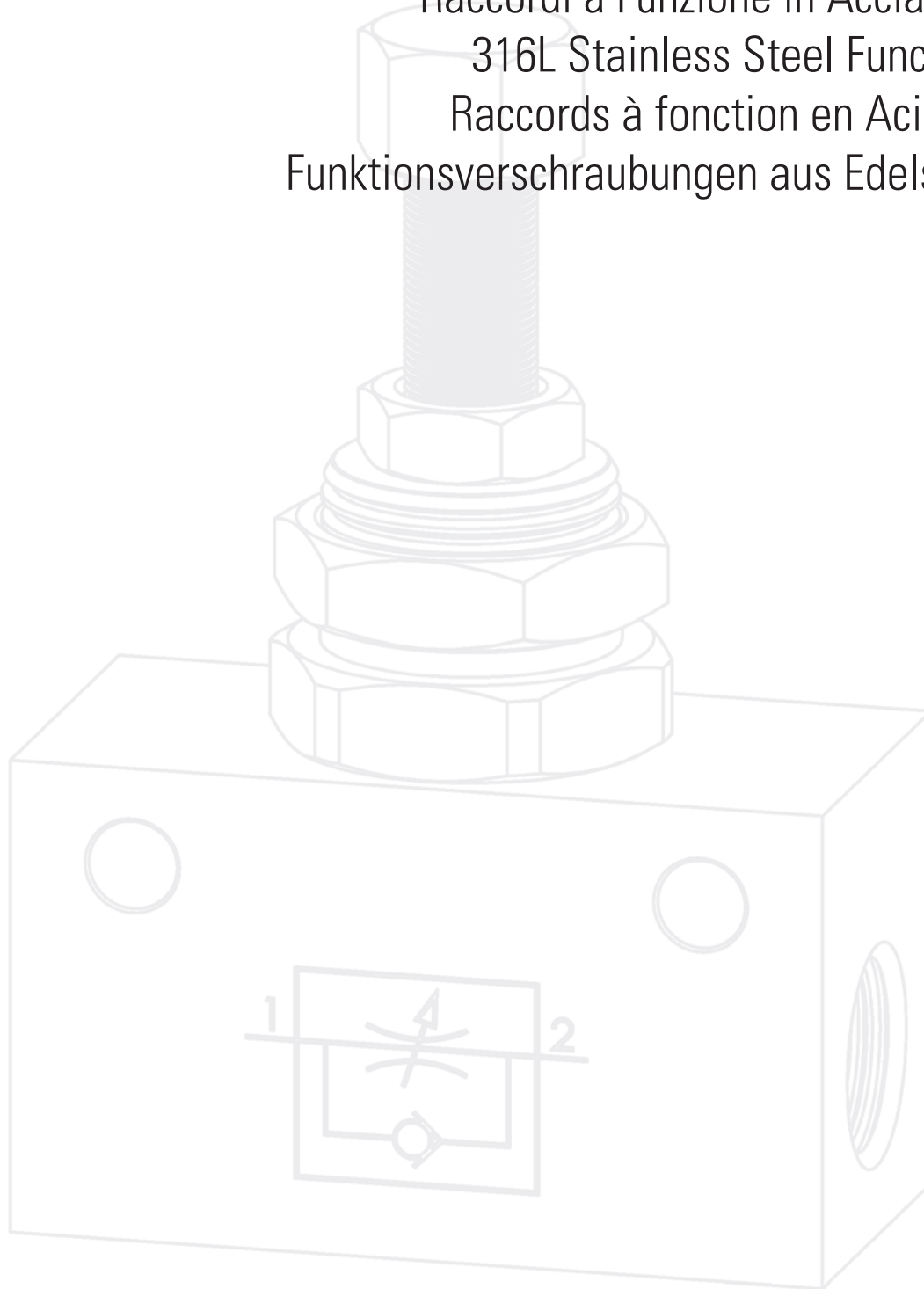

.../C = Regolazione del flusso in Uscita
 Meter out flow control
 Réducteur de débit fonctionnant à échappement
 Abluftdrosselung

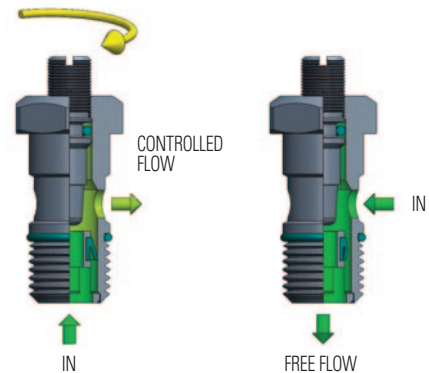

.../N = Regolazione del flusso in Ingresso
 Meter in flow control
 Réducteur de débit fonctionnant à l'admission
 Zuluftdrosselung

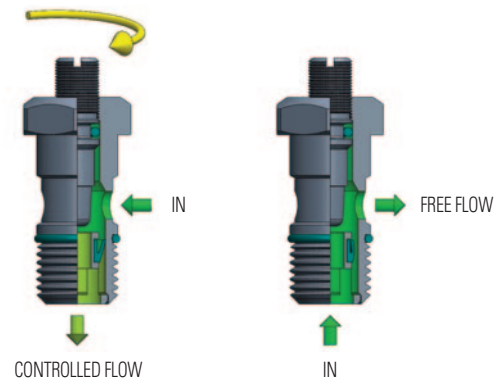

.../B = Regolazione del flusso in entrambe le direzioni
 Bidirectional flow control
 Réducteur de débit bidirectionnel
 Beidseitige Drosselung

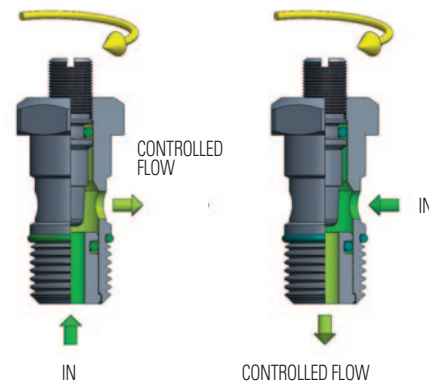

Questi dispositivi offrono la possibilità di regolare la portata d'aria in un circuito pneumatico. In base al tipo di regolatore impiegato, la regolazione può avvenire in entrambi i sensi (Regolatore Bidirezionale), oppure in un unico senso (Regolatore Unidirezionale). I Regolatori di Flusso Unidirezionali, risultano particolarmente adatti per la regolazione della velocità di cilindri pneumatici.

They can adjust the flow in a pneumatic circuit. Depending on the flow control used, the setting can be made both ways (Bidirectional Flow Control), or just one way (Unidirectional Flow Control). The Unidirectional Flow Control is particularly used to adjust the speed of pneumatic cylinders.

Leur fonction est d'assurer le réglage du débit dans un circuit pneumatique. Selon le réducteur employé, le réglage peut être effectué dans les deux sens (réducteur bidirectionnel) ou dans un seul sens (réducteur unidirectionnel). Le réducteur unidirectionnel est très utilisé pour le réglage de la vitesse de sortie de tige du vérin pneumatique.

Das Drosselrückschlagventil regelt den Durchfluss in einer pneumatischen Anlage. Je nach dem Drosselventil, kann die Drosselung auf beiden Seiten (beidseitiges Drosselrückschlagventil) oder einfach auf einer Seite erfolgen. (einseitiges Rückschlagventil). Besonders geeignet ist das einseitige Drosselrückschlagventil für die Regulierung der Zylindergerwindigkeit.

1	2	3	4	5
Corpo Body Corps Körper	Spillo Needle Epingle Nadel	Bussola Cartridge Cartouche Patrone	Guarnizioni Seals Joint d'étanchéité Dichtung	Rondella Gasket Rondelle Dichtring
Acciaio Inox AISI 316L (1.4404) Stainless Steel AISI 316L (1.4404) Acier Inox AISI 316L (1.4404) Edelstahl AISI 316L (1.4404)			FPM FPM FPM FPM	PTFE PTFE PTFE PTFE

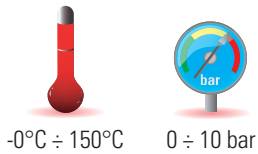

-0°C ÷ 150°C

0 ÷ 10 bar

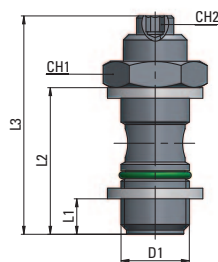
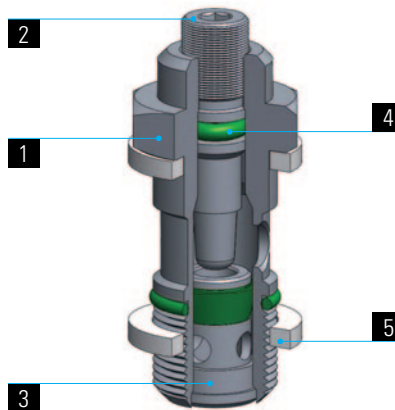

Tipo	D1	L1	L2	L3 max	CH1	CH2	g
15 00 18	G1/8	5,5	25	36	14	2,5	17
15 00 14	G1/4	6,5	27,5	42	17	3	32,1

Disponibile nelle versioni:

.../C



.../V



.../B



SPECIFICHE TECNICHE

Tubi di collegamento consigliati:
variabili in funzione del tipo di raccordo collegato al regolatore.

Campi di applicazione:
impianti pneumatici alimentati con aria filtrata e lubrificata.

DATA SHEET

Recommended tubings:
according to the fitting connected to the flow control.

Application field:
pneumatic installations fed with filtered, lubricated air.

REINSEIGNEMENTS TECHNIQUES

Tube conseillé:
en fonction du raccord monté sur le réducteur.

Domaines d'application:
circuits pneumatiques avec air filtré et lubrifié.

TECHNISCHE AUSKÜNFTE

Empfohlene Schläuche:
die Schläuche werden durch die am Drosselrückschlagventil montierte verschraubung bestimmt.

Anwendungsbereiche:
pneumatische Anlage mit gefilterter und geölter Druckluft.

1	2	3	4	5
Corpo Body Corps Körper	Spillo Needle Epingle Nadel	Bussola Cartridge Cartouche Patrone	Guarnizioni Seals Joint d'étanchéité Dichtung	Anello Banjo Ring Banjo Steckverschraubungen
Acciaio Inox AISI 316L (1.4404) Stainless Steel AISI 316L (1.4404) Acier Inox AISI 316L (1.4404) Edelstahl AISI 316L (1.4404)			FPM FPM FPM FPM	Raccordo Automatico serie MX MX line push-in fittings Raccords instantanés série MX MX Steckverschraubungen

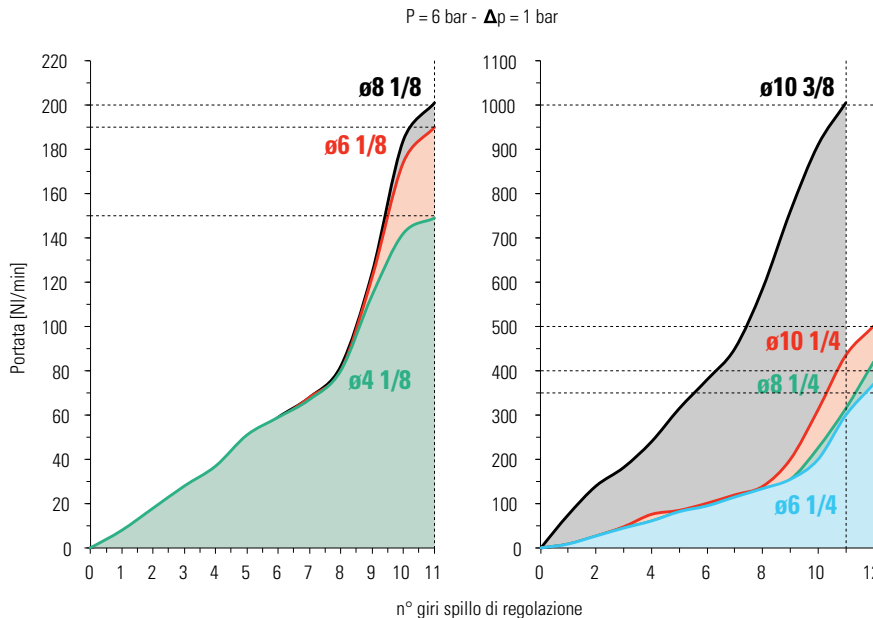
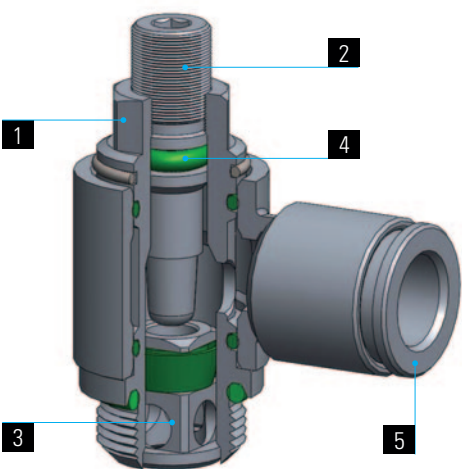
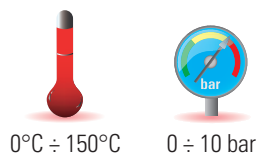

L'anello rimane orientabile anche dopo l'installazione del regolatore.
The banjo ring swivels also after flow control installation.
Les banjos peuvent être orientés après l'installation du réducteur.
Der Schwenkring kann nach der Montage des Drosselrückschlagventiles noch orientiert werden.

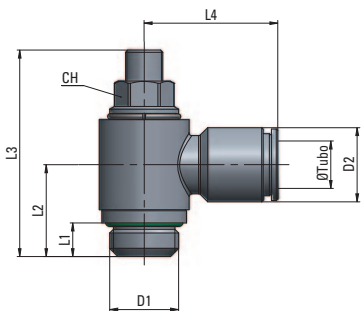

Tipo	Øe Tubo	D1	D2	L1	L2	L3 max	L4	CH	g
18 04 18	4	G1/8	9	5	15,5	32	19,5	9	29
18 06 18	6	G1/8	12	5	15,5	32	22	9	27
18 06 14	6	G1/4	12	6,5	17,5	40	23,5	10	49
18 08 18	8	G1/8	14	5	15,5	32	22,5	9	31
18 08 14	8	G1/4	14	6,5	17,5	40	24	10	49
18 10 14	10	G1/4	16	6,5	17,5	40	26,5	10	53
18 10 38	10	G3/8	16	9	22	52	28	14	86

Disponibile nelle versioni:

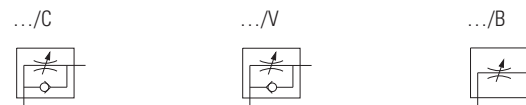

SPECIFICHE TECNICHE

Tubi di collegamento consigliati:
Tubo in PVDF, Tubo in PTFE.

Campi di applicazione:
impianti pneumatici alimentati con aria filtrata e lubrificata.

DATA SHEET

Recommended tubings:
PVDF and PTFE tubings.

Application field:
pneumatic installations fed with filtered, lubricated air.

REINSEIGNEMENTS TECHNIQUES

Tubes conseillés:
Tube PVDF et Tube PTFE.

Domaines d'application:
circuits pneumatiques avec air filtré et lubrifié.

TECHNISCHE AUSKÜNFTE

Empfohlene Schläuche:
PVDF, PTFEschläuch.

Anwendungsbereiche:
pneumatische Anlage mit gefilterter und geölter Druckluft.

1	2	3	4	5	6
Corpo Body Corps Körper	Regolatore Needle valve Réducteur de débit Drosselventil	Pomolo Handwheel Volant moleté Rändelkopf	Spillo Needle Epingle Nadel	Dado Nut Ecrou Überwurfmutter	Guarnizioni Seals Joint d'étanchéité Dichtung
Acciaio Inox AISI 316L (1.4404) Stainless Steel AISI 316L (1.4404) Acier Inox AISI 316L (1.4404) Edelstahl AISI 316L (1.4404)					FPM FPM FPM FPM

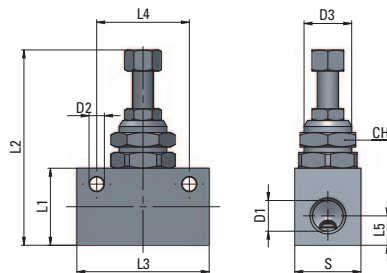
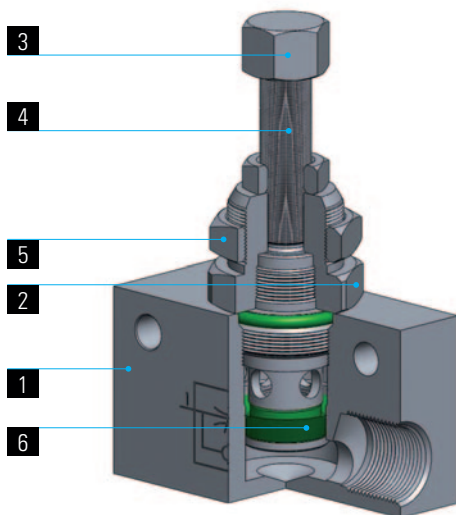

Tipo	D1	D2	D3	L1	L2max	L3	L4	L5	S	CH	g Δ
21 00 18	G1/8	4,5	M12x0,75	20	56	34	24	7,5	15	14	72,5
21 00 14	G1/4	5,5	M18x1,5	30	75	50	35	12	25	22	281,4

Disponibile nelle versioni:

.../U =

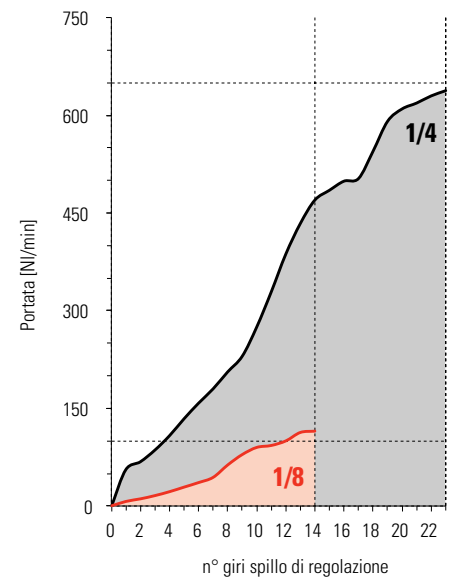

.../B

P = 6 bar - Δp = 1 bar

SPECIFICHE TECNICHE

Tubi di collegamento consigliati:
variabili in funzione del tipo di raccordo collegato al regolatore.

Campi di applicazione:
impianti pneumatici alimentati con aria filtrata e lubrificata.

DATA SHEET

Recommended tubings:
according to the fitting connected to the flow control.

Application field:
pneumatic installations fed with filtered, lubricated air.

REINSEIGNEMENTS TECHNIQUES

Tubes conseillés:
en fonction du raccord monté sur le réducteur.

0 ÷ 10 bar
Domaines d'application:
circuits pneumatiques avec air filtré et lubrifié.

TECHNISCHE AUSKÜNFTE

Empfohlene Schläuche:
die Schläuche werden durch die am Drosselrückschlagventil montierte Verschraubung bestimmt.

Anwendungsbereiche:
pneumatische Anlage mit gefilterter und geölter Druckluft.